

BSZ-KH



Concrete Highway Divider Clamp BSZ-KH

With this mechanical grab barrier walls can be gripped absolutely safe without leaving any marks on the concrete elements.

Even densely stacked asymmetrically elements can be lifted and installed easily due to the slim design of gripper arms. Thus more barrier elements can be loaded and transported on the truck, which results in a considerable reduction in costs!

- ▷ High rationalisation of staff costs.
- ▷ Rapid repetitive sequences

Standard Specifications:

- ▷ Lifting eye for attaching to crane hook.
- ▷ Automatic release for the fully automatic switch over from "full" to "empty".
- ▷ Leaves no black marks.

BSZ-KH

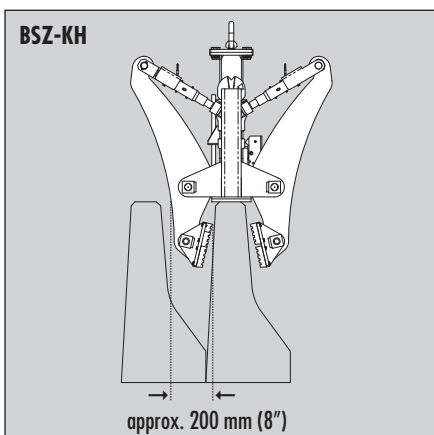

Type	Gripping Range* W mm (in)	Working Load Limit WLL kg (lbs)	Dead Weight kg (lbs)	Order-Number
BSZ-KH-4.5	150 – 210 (6 – 8 1/4")	4.500 (9,900)	430 (950)	5310.0410
BSZ-KH-6.0	150 – 210 (6 – 8 1/4")	6.000 (13,200)	450 (990)	5310.0411

Concrete Highway Divider Clamp BSZ-KH-ULTRA

Suitable for gripping and transporting barrier walls of the type "BSWF-ULTRA" in connection with any carrier machine.

- ▷ Purely mechanical operation.
- ▷ Automatic release for the fully automatic switch over from "full" to "empty".
- ▷ With lifting eye for hoists.

BSZ-KH-ULTRA-I: for gripping individual elements.

BSZ-KH-ULTRA-II: With central bar, coated entirely with rubber – for transport of 2 elements simultaneously.

BSZ-KH-ULTRA-I

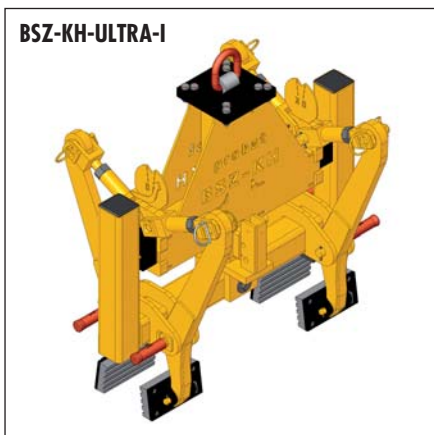

Type	Element	Working Load Limit WLL kg (lbs)	Dead Weight kg (lbs)	Order-Number
BSZ-KH-ULTRA-I	BSWF-ULTRA	1,500 (3,300)	280 (620)	5310.0330
BSZ-KH-ULTRA-II	BSWF-ULTRA	3,000 (6,600)	361 (800)	5310.0329

The use of additional element types must be tested, and this can be requested.

Hydraulic Concrete Highway Divider Clamp BSZ-H

Suitable for gripping and transporting single-sided and double-sided barrier walls of the type "New Jersey" in connection with any carrier machine such as diggers or truck loading cranes.

- ▷ Slim design for picking up closely arranged elements.
- ▷ Equipped with a hydraulic accumulator for perfectly reliable gripping.

BSZ-H-5.1

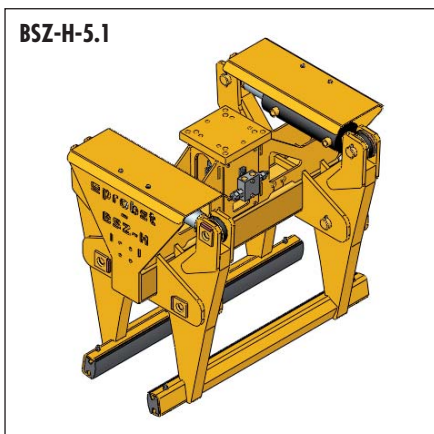

Type	Element	Working Load Limit WLL kg (lbs)	Dead Weight kg (lbs)	Order-Number
BSZ-H-2.0	DB 50 + DB 65 S	2,000 (4,400)	235 (520)	5640.0003
BSZ-H-5.1	DB 80, DB 80 AS, DB 80 AS-A, DB 80 AS-E, DB 80 AS-F, DB 80 AS-R, DB 80 E, DB 80 F, DB 100, DB 100 AS-R, DB 100 S	5,100 (11,200)	ca. 400 (approx. 880)	5640.0002

The use of additional element types must be tested, and this can be requested.

*Gripping range indicates the minimum and maximum pack measurements of building materials, which can be picked-up with this grab.