

Operating instructions

STAR LIFTKET Electric chain hoist



MADE IN GERMANY BY LIFTKET

The electric chain hoist may only be operated by persons who have read and understood the entire operating instructions.

LIFTKET Hoffmann GmbH
Dresdener Straße 66-68
04808 Wurzen
GERMANY
Telephone: +49 (0) 3425 8924 0
Fax: +49 (0) 3425 8924 99
Email: info@liftket.de
Internet: www.liftket.de

Translation of the original operating instructions

BA STAR LIFTKET 05/2024 en-GB

Table of contents

1	General information	7
1.1	Information about the operating instructions.....	7
1.2	Customer service.....	7
1.3	Fasteners, replacement parts and accessories.....	7
1.4	Right-hand thread.....	7
1.5	Definition of categories of persons.....	7
1.6	Test book.....	8
2	Safety	9
2.1	Intended use of electric chain hoists.....	9
2.2	Prohibitions for use.....	10
2.3	Instructions for use.....	11
2.4	EMERGENCY STOP.....	12
2.5	Symbols and signal words.....	12
2.6	Pictograms.....	13
2.7	Warning sign.....	13
2.8	Employers' liability insurance association regulations.....	14
2.9	Responsibilities of the operating company.....	14
3	Technical overview	14
3.1	Structure.....	14
3.2	Attachment parts.....	15
3.3	Completion and classification.....	16
3.4	Entertainment application.....	16
3.5	Arrangement of the load chain.....	18
3.6	Type plate.....	18
3.7	Explanation of type designation.....	19
3.8	Conditions of use.....	19
3.9	Electrical data.....	19
3.9.1	Lift motor.....	19
3.9.2	Traversing motor.....	20
3.10	Main dimensions.....	21
3.11	Noise level.....	22
4	Assembly instructions	23
4.1	Scope of delivery, transport and storage.....	23
4.1.1	Scope of delivery.....	23
4.1.2	Transport.....	23
4.1.3	Storage.....	23
4.2	Requirements.....	23
4.2.1	Safety instructions for assembly.....	23
4.2.2	Qualification of the assembler.....	24
4.2.3	Unpacking the goods.....	24
4.2.4	Inspection before assembly.....	25

4.3	Lifting gear.....	25
4.3.1	Hook tackle.....	25
4.3.2	Hook block.....	26
4.3.3	Load chain.....	27
4.4	Chain box.....	31
4.4.1	Chain box assembly information.....	31
4.4.2	Chain box Flip bag.....	31
4.4.3	Fabric chain box.....	32
4.4.4	Sheet steel chain box.....	34
4.5	Stationary suspension.....	34
4.5.1	Suspension hook.....	35
4.5.2	Single-hole suspension lug.....	35
4.5.3	Suspension lug.....	36
4.6	Suspension with trolley.....	36
4.6.1	Trolley types.....	37
4.6.2	Type designation.....	37
4.6.3	Curve radii.....	37
4.6.4	Arrangement.....	38
4.6.5	Assembling the trolley.....	38
4.7	Gear ventilation.....	42
4.8	Electrical connection.....	43
4.8.1	General information.....	43
4.8.2	Fuse protection.....	43
4.8.3	Connecting.....	43
4.8.4	Pendant control.....	44
4.8.5	Setting the gear limit switch.....	44
5	Operation.....	44
5.1	Initial commissioning.....	44
5.1.1	Requirements for initial commissioning.....	44
5.1.2	Check before the initial commissioning.....	45
5.1.3	Commissioning test.....	45
5.1.3.1	Scope of the test.....	45
5.1.3.2	Test sequence.....	46
5.2	Operation.....	46
5.2.1	Qualification of operating personnel.....	46
5.2.2	Safety instructions for operation.....	47
5.2.3	Pendant control.....	48
5.2.4	Radio remote control.....	49
5.2.5	Attaching the load.....	49
5.3	Operation.....	50
5.3.1	Proper operation.....	50
5.3.2	Residual risks.....	50

5.3.3	Working with the hoist.....	51
5.3.3.1	Start of work.....	51
5.3.3.2	Operating information.....	52
5.3.3.3	Decommissioning.....	53
5.4	Duty cycle.....	53
5.4.1	Duty cycle of the electric chain hoist.....	53
5.4.1.1	Short-term operation according to FEM 9.683.....	54
5.4.1.2	Intermittent operation according to FEM 9.683.....	54
5.4.1.3	Calculation of operating and pause times.....	55
5.4.2	Trolley duty cycle.....	55
5.5	Tests.....	55
5.5.1	Type test.....	55
5.5.2	Guidelines and standards.....	56
5.5.3	Assignment to the relevant accident prevention regulations.....	56
5.5.4	Testing when used in accordance with DGUV V54, Section 23.....	57
5.5.5	Testing when used in accordance with DGUV V52, Section 25 and 26.....	57
6	Maintenance.....	57
6.1	Replacement parts.....	57
6.2	Maintenance intervals – Table.....	58
6.3	Maintenance work.....	59
6.3.1	Housing.....	60
6.3.2	trolley.....	60
6.3.3	Load and suspension hooks.....	60
6.3.4	Load chain.....	61
6.3.4.1	Load chain wear test.....	61
6.3.4.2	Chain end fastener.....	62
6.3.4.3	Replacing the load chain.....	62
6.3.5	Chain guide and downholder.....	68
6.3.6	Rubber buffer.....	68
6.3.7	Chain box.....	68
6.3.8	Electric limit switch.....	69
6.3.9	Gear limit switch.....	69
6.3.10	Brake.....	70
6.3.10.1	Simple brake.....	70
6.3.10.2	Double brake.....	71
6.3.10.3	Trolley brake.....	73
6.3.10.4	Manual ventilation.....	73
6.3.10.5	Functional inspection of the brake.....	73
6.3.10.6	Fault correction.....	74
6.3.11	Clutch.....	74
6.3.11.1	Structure.....	74
6.3.11.2	Replacing the clutch.....	75
6.3.11.3	Adjusting the clutch.....	76

6.3.11.4	Tests.....	77
6.3.11.5	Trigger limit test.....	78
6.3.12	Motor.....	78
6.3.13	Lubrication.....	81
6.3.13.1	Lubricating the load chain.....	81
6.3.13.2	Lubricating the trolley.....	82
6.3.13.3	Gear lubrication.....	83
6.3.13.4	Lubricating the load and suspension hooks.....	84
6.3.14	Control.....	84
6.3.14.1	Checking the control.....	84
6.3.14.2	Opening the terminal compartment.....	84
6.3.14.3	Control arrangement.....	85
6.3.14.4	Direct control.....	85
6.3.14.5	Contactors control.....	85
6.3.14.6	Circuit board control.....	86
6.4	Troubleshooting and fault correction.....	86
6.5	Reaching the end of the theoretical service life.....	89
6.5.1	Remaining service life.....	89
6.5.2	Calculation of remaining service life.....	89
6.6	Disassembly and disposal.....	90
7	Directives and standards applied.....	90
7.1	General validity EU.....	90
7.2	European Directives.....	90
7.3	Harmonised standards.....	90
7.4	Standards and technical specifications.....	91
8	Example declaration of conformity.....	92
9	Example declaration of incorporation.....	93

1 General information

You have purchased a quality product.

This electric chain hoist was built according to the current state of the art, and it fulfils the requirements of the EC Machinery Directive.

1.1 Information about the operating instructions

The operating instructions serve to enable safe work on and with the electric chain hoist. They contain useful information for the operator and user regarding transport, storage, installation, commissioning, operation and maintenance. The operating instructions are part of the device.

The electric chain hoist may only be operated by persons who have read and understood the entire operating instructions.

The operating instructions must be accessible to the operating personnel at all times and must be stored in the immediate vicinity of the electric chain hoist. They must always be complete and in a perfectly legible state.

1.2 Customer service

If you have any queries or technical questions about our products, please contact our sales department.
sales@liftket.de

For replacement part orders please use the LIFTKET online shop on our website.

Please contact our service department for any questions regarding replacement parts. Have the serial number of the device ready (see type plate).
service@liftket.de

1.3 Fasteners, replacement parts and accessories

Use only the original fasteners, replacement parts, wear parts and accessories from the manufacturer. Only these parts are covered by the warranty.

! NOTICE

The manufacturer does not assume any liability for damages caused by the use of non-original parts and accessories.

1.4 Right-hand thread

Unless expressly described otherwise, all screw connections used are right-hand threads.

1.5 Definition of categories of persons

Manufacturer

Machinery Directive 2006/42/EC, Article 2 i:

“Any natural or legal person who designs and/or manufactures machinery or partly completed machinery covered by this Directive and is responsible for the conformity of the machinery or the partly completed machinery with this Directive with a view to its being placed on the market, under his own name or trademark or for his own use. In the absence of a manufacturer as defined above, any natural or legal person who places on the market or puts into service machinery or partly completed machinery covered by this Directive shall be considered a manufacturer.”

Test book

Operator	The operator (contractor/company) is the person who operates or owns the machine/plant or has it operated by suitable and instructed persons. In this sense, private, public and semi-public owners are to be regarded as operators. The operator bears responsibility for the machinery and is liable for any failure to comply with a requirement, regulation or instruction.
Operating personnel	Operating personnel are persons who have been instructed by the operator and who work with the electric chain hoist.
Specialist/maintenance personnel	Specialist/maintenance personnel are persons who have been tasked by the operator with assembly, maintenance, troubleshooting or other tasks. They must be trained by the operator for these tasks and have the necessary specialist knowledge.
Electrician	An electrician is a person with the technical training, knowledge and experience necessary to recognise and avoid dangers that may arise when working with electricity.
Qualified person	<p>In accordance with the German Operational Safety Ordinance (Betriebssicherheitsverordnung), a qualified person is a person who, through their professional training, professional experience and current or recent professional activity, has the necessary specialist knowledge for testing work equipment.</p> <ul style="list-style-type: none">■ Qualified persons include the manufacturer's service technicians and specialists with particular training. Hoists in accordance with DGUV V54 must be checked by a qualified person before the first commissioning and after substantial changes.
Expert	<p>In accordance with the German Operational Safety Ordinance, an expert is a qualified person who has also completed training as an engineer or has similar knowledge and experience in the field to which the activity relates; has at least three years' experience in the design, construction, maintenance or testing of cranes and has been involved in the testing activities of a registered inspector for at least six months; has sufficient knowledge of the relevant regulations and rules; has the equipment and documentation required for the testing; and keeps their professional knowledge up to date.</p> <ul style="list-style-type: none">■ In addition to TÜV experts, only persons authorised as experts by the employers' liability insurance associations and registered inspectors in accordance with the Operational Safety Ordinance are considered experts for the inspection of cranes.■ The registered inspector for the inspection of cranes must be certified by a body accredited according to DIN EN ISO 17024 for personal certification or be authorised by an institution of the statutory accident insurance (e.g. according to Section 28 DGUV V52 and 53 in conjunction with DGUV G309-005).■ Cranes according to DGUV V52 must be checked by an expert before the first commissioning and after substantial changes. The crane is to be tested in accordance with DIN EN 15011.
1.6 Test book	<p>In the Federal Republic of Germany, every hoist must have a fully completed test book in accordance with the applicable laws and regulations. The results of the installation and commissioning test, recurring inspections, conversions and repairs must be documented in the test book.</p>

2 Safety

This chapter contains all important safety instructions for the safe and fault-free operation of the electric chain hoist and its components.

The electric chain hoist and its components are constructed according to the recognised rules of technology and are operationally reliable at the time of placing on the market. However, incorrect or improper use may render the system unsafe. The operator is responsible for ensuring that their staff and the operating personnel are familiar with the operating instructions, and have read and understood them.

Improper modifications, extensions or conversions of the electric chain hoist and its components are prohibited.

2.1 Intended use of electric chain hoists

The electric chain hoist may only be used for vertically lifting and lowering and, in conjunction with a trolley, for horizontally moving loads. Any use beyond this, in particular the non-observance of the prohibitions for use, is considered improper as it may cause harm to life and limb. The manufacturer shall not be liable for any resulting damage; the associated risk shall be borne by the user.

The electric chain hoist may only be operated by persons who have been instructed by the operator. They must be familiar with these operating instructions and have access to them at all times.

The operator must ensure that the attachment points of the electric chain hoist are designed in such that they can reliably withstand the forces acting on them.

The electric chain hoist may only be operated if it is suspended in accordance with applicable regulations and it is thus ensured that the mass of the outgoing chain is sufficient to cause it to safely run out of the chain hoist during the lifting movement. Failure to observe this instruction would lead to a jam in the chain guide and thus to damage of the electric chain hoist.

The maximum load capacity (WLL) must not be exceeded when using the electric chain hoist. The duty cycle and maximum number of switching cycles must be adhered to.

Prior to commissioning, it must be ensured that all electrical connections are correctly arranged and that all cables are intact. It must be possible to disconnect the system from power via a mains circuit breaker.

Work on the electric chain hoist must be carried out exclusively by qualified persons after the crane main switch has been switched off and locked and the work area has been cordoned off.

Whether the electric chain hoist was installed with or without a trolley is the basis for assessing whether the lifting equipment is a crane or a power-driven hoist. When changing the installation form of the electric chain hoists, it must always be checked whether this also changes the classification. The tests required prior to initial commissioning or after substantial changes, as well as the recurring inspections, shall be carried out as a test for a crane or as a test for a power-driven hoist, depending on which equipment is fitted.

! NOTICE

The manufacturer assumes no liability for damage and malfunctions caused by:

- Improper operation
- Unauthorised changes to the electric chain hoist
- Improper work on and with the electric chain hoist
- Operating errors
- Failure to comply with the operating instructions

 **CAUTION**

The operating instructions must have been read and understood before using the electric chain hoist.

2.2 Prohibitions for use

 **WARNING****Danger of injury**

Transporting persons is prohibited!

 **WARNING****Risk of falling loads**

Falling loads can lead to death or serious physical injuries.

- No persons should stand under the load.
- No persons should enter the hazard area.

 **WARNING****Risk of personal injury and damage to property**

Deliberately triggering the safety device (slip clutch) during normal operation is prohibited.

 **WARNING****Risk of crushing and shearing injuries**

Touching moving parts constitutes a risk of crushing and shearing injuries.

- Do not touch the chain during operation.
- No persons should enter the hazard area.

 **WARNING****Risk of chain tear**

Falling loads can lead to death or serious physical injuries.

- Do not use the load chain for attaching or looping loads.
- The load chain must not run across edges.
- The load chain must not be bent, damaged or worn.
- The load chain must not be extended or repaired.

 **WARNING**

Ignoring the following prohibitions for use can lead to death or serious physical injuries.

- It is forbidden to move loads which are greater than the nominal load.
- The electric chain hoist must not be operated with a longer chain length than that indicated on the chain box.
- Pulling loads diagonally or towing loads is prohibited.
- Breaking away loads is prohibited.
- Lifting lids of vessels under negative pressure is prohibited.
- When operating load magnets or grippers on the electric chain hoist, you must ensure that the nominal load is never exceeded. Suspended loads must not be dropped.
- Traversing with the trolley by pulling on the pendant control or control cable, even if these are strain-relieved, is prohibited.
- Do not lower the load attachment device until the chain slackens. The load chain must not be twisted.

2.3 Instructions for use

 **CAUTION**

Failure to observe the following instructions for use may result in damage to property and minor or moderate physical injuries.

- Do not operate the electric chain hoist in jog mode.
- Do not operate the electric chain hoist with a voltage other than that indicated on the type plate.
- All safety instructions must be clearly visible and may not be removed or concealed. Damaged signs must be replaced.
- Secure the electric chain hoist properly.
- Lubricate the load chain according to the maintenance specifications.

 **CAUTION**

Failure to observe the following instructions for use may result in damage to property and minor or moderate physical injuries.

- Before lifting, position the load vertically below the electric chain hoist.
- Do not move the load until it is securely attached and no person is present in the hazard area.
- Always lift loads at the lowest available lifting speed. Slack lashing must first be tensioned before lifting.
- Loads must be balanced before the lifting process.
- During the procedure, the load must always be observed by the operating personnel or a second person in contact with the operating personnel.
- Do not leave the attached load unattended, or take special precautions.

⚠ CAUTION

Failure to observe the following instructions for use may result in damage to property and minor or moderate physical injuries.

- Do not touch the electric chain hoist during operation. Risk of burns.
- If you notice unusual behaviour by the electric chain hoist, switch it off via the EMERGENCY STOP button. Report malfunctions to the appropriate persons.
- After pressing the EMERGENCY STOP button, the cause of the problem must be rectified by a qualified person. The EMERGENCY STOP button must only be reset after this has been done.
- The EMERGENCY STOP button must not be used for regular shutdown.
- Do not operate the electric chain hoist outside the operational limit positions.
- Do not use the load chain or load hook as electric grounding.
- Do not touch the load chain or load hook with a live welding electrode.

⚠ CAUTION

Failure to observe the following instructions for use may result in damage to property and minor or moderate physical injuries.

- Consult the manufacturer before using the electric chain hoist in aggressive environments.
- Consult the manufacturer before transporting molten material or similar dangerous goods.
- Repairing or dismantling lifted loads is prohibited.
- Only use original parts from the manufacturer for repairs.
- Exceeding the permitted duty cycle is not permitted.
- It is not permitted to operate the hoist after exceeding the accident prevention test date.

2.4 EMERGENCY STOP

Controllers with an EMERGENCY STOP function in accordance with DIN EN 60204-32 have a red mushroom-shaped EMERGENCY STOP button on the pendant control.

! NOTICE

Pressing the EMERGENCY STOP button does not replace the mandatory system shutdown after completion of work by means of a main switch.

2.5 Symbols and signal words

The following symbols and signal words refer to possible hazard points and give advice on avoiding personal injury and damage to property.

⚠ DANGER**Type and source of danger**

This symbol represents an imminent danger that can lead to serious injuries or death.

- Always observe and follow the instructions.
- Be particularly alert and careful.

⚠ WARNING

Type and source of danger

This symbol represents a potentially dangerous situation that may lead to serious injuries or death.

- Always observe and follow the instructions.
- Be particularly alert and careful.

⚠ CAUTION

Type and source of danger

This symbol represents a potentially dangerous situation which may result in moderate or minor injuries or damage to property.

- Always observe and follow the instructions.
- Be particularly alert and careful.

! NOTICE

Type and source of danger

Operating safety of the device in jeopardy.

- Information for correct handling
- Observe in order to avoid faults and damage

i Topic

Practical information and instructions for effective and low-wear operating of the device.

2.6 Pictograms



Fig. 1: Safety symbols

The following safety symbols are affixed to each electric chain hoist.

- 1 Warning: dangerous electrical voltage.
- 2 Read the operating instructions before using the electric chain hoist.
- 3 Grease the chain at regular intervals.
- 4 Transporting persons is prohibited.
- 5 Lifting or transporting loads over persons is prohibited.

2.7 Warning sign

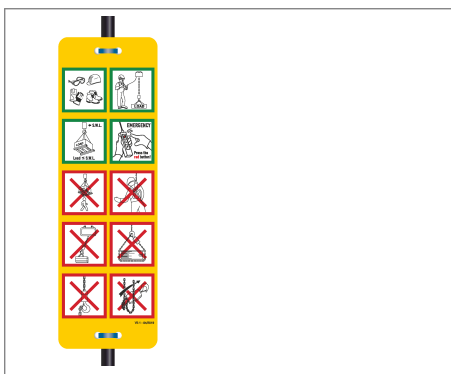

Fig. 2: Warning sign

The warning sign is supplied by the manufacturer along with the electric chain hoist.

If the sign is not fastened to the pendant control of the electric chain hoist, order a replacement from the manufacturer or distributor.

Affix the new sign to the pendant control of the electric chain hoist.

⚠ WARNING

Read and follow all warnings on the electric chain hoist.

Structure

2.8 Employers' liability insurance association regulations

The assembly, commissioning, testing and maintenance of electric chain hoists in the Federal Republic of Germany are subject to the following regulations and instructions.

DGUV Vorschrift 1 (2013)	Principles of prevention
DGUV Vorschrift 3 (1997)	Electrical installations and equipment
DGUV Vorschrift 52 (2000)	Cranes
DGUV Vorschrift 54 (1997)	Winches, lifting and pulling equipment
DGUV Regel 100-500 (2021)	Operation of work equipment
DGUV Regel 109-017 (2020)	Operation of load attachment devices and lashing in hoist operation
DGUV Grundsatz 309-001 (2012)	Inspection of cranes
BetrSichV (2015)	German Operational Safety Ordinance – Ordinance on health and safety when using working equipment
TRBS 1203 (2021)	Persons qualified to perform inspections

2.9 Responsibilities of the operating company

The essential obligations of the operator are:

- The operator must procure proper and safe machines in accordance with the Machinery Directive.
- The operator must ensure that the machine is inspected before commissioning.
- The operator is required to prepare work instructions; the operating instructions of the manufacturer serve as information. Key contents of these instructions include: operation, maintenance, shutdown, behaviour in the case of faults and accidents.
- The operator is to conduct a risk assessment, the resulting document of which is to include protective measures and recurring inspection periods, and shall instruct their employees on this basis.

It is strongly advised to involve the safety specialist before procurement and commissioning.

Machinery used outside the European Union must comply with the applicable regional regulations and the provisions on the installation, operation, maintenance and disposal of the machinery that apply at the place of use.

3 Technical overview

3.1 Structure

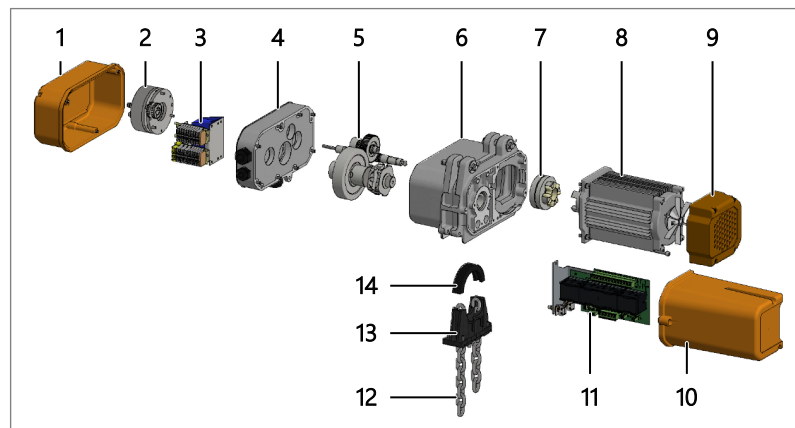
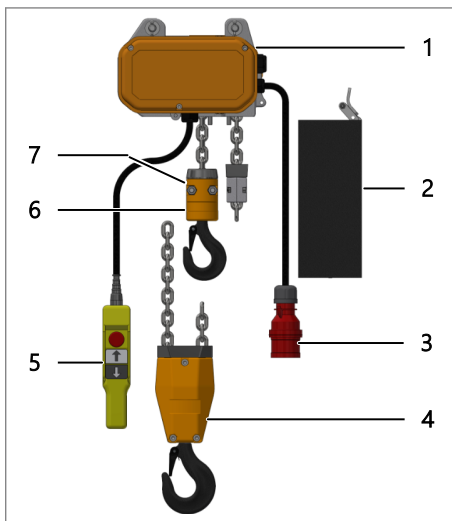

Fig. 3: Structure of the electric chain hoist

- 1 Brake cap
- 2 Brake
- 3 Control on the brake side

- 4 Gear cover
- 5 Gear
- 6 Housing
- 7 Clutch
- 8 Motor with fan
- 9 Fan cap
- 10 Control cap
- 11 Control on the motor side
- 12 Load chain
- 13 Chain guide
- 14 Downholder

3.2 Attachment parts



- 1 Lifting device
- 2 Chain box
- 3 Mains connection
- 4 Hook block
- 5 Pendant control with EMERGENCY STOP
- 6 Hook tackle
- 7 Lift limiter

Fig. 4: Attachment parts

EASY CONNECT plug-and-play system

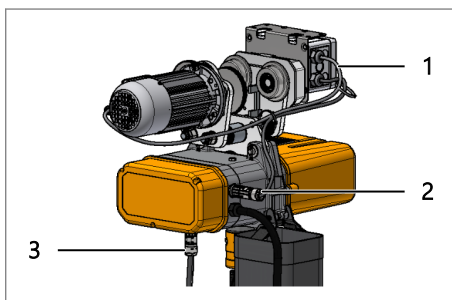

- 1 Connection of the trolley contactor control to the travelling motor
- 2 Connection of the electric chain hoist to the trolley contactor control
- 3 Connection of the pendant control to the electric chain hoist

Fig. 5: EASY CONNECT

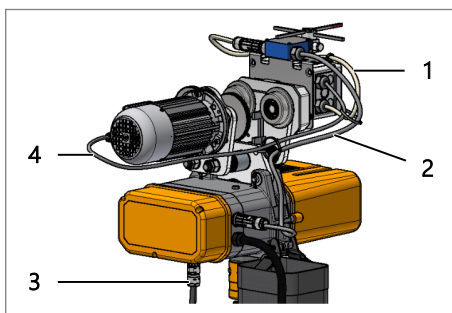

- 1 Connection of the trolley contactor control to the trolley limit stop
- 2 Connection of the electric chain hoist to the trolley limit stop
- 3 Connection of the pendant control to the electric chain hoist
- 4 Connection of the trolley contactor control to the travelling motor

Fig. 6: EASY CONNECT with trolley limit stop

3.3 Completion and classification

The easy-to-assemble modular system enables the conversion of the electric chain hoists to single fall or double fall versions.

The electric chain hoists can be used as follows:

- **stationary** as a power-driven lifting device (according to DGUV V54)
or
- **with trolleys** as a crane (according to DGUV V52)

The classification of the hoist depends on what equipment is fitted.

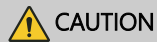

CAUTION

New classification by conversion

Attaching a trolley or mounting it on swivel arms, jibs, etc. turns a power-driven hoist into a crane.

Any non-stationary use makes the lifting device a crane.

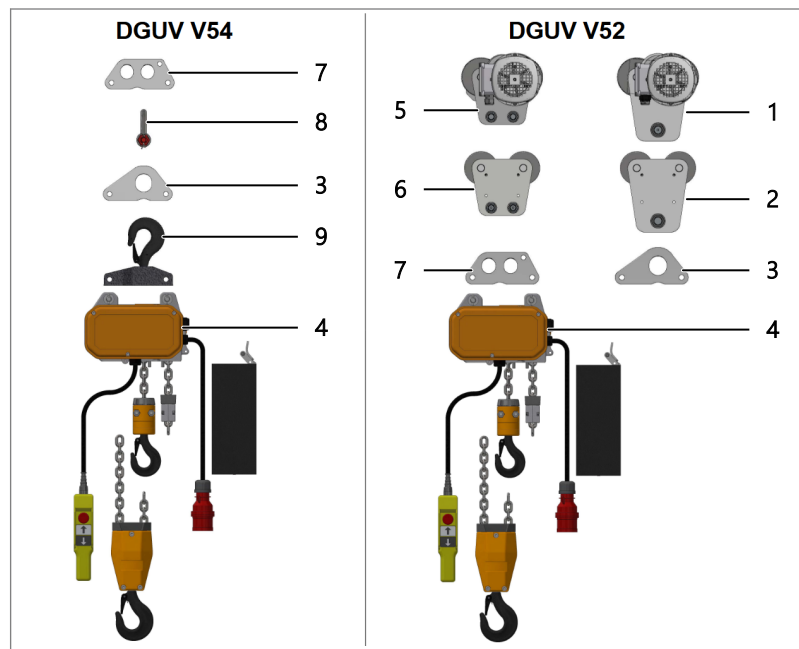

Fig. 7: Completion options

- 1 Single-bolt electric trolley
- 2 Single-bolt manual trolley
- 3 Single-hole suspension lug
- 4 Lifting device
- 5 Electric trolley
- 6 Manual trolley
- 7 Suspension lug
- 8 Shackle
- 9 Suspension hook

3.4 Entertainment application

The electric chain hoists can be used in the standard position and as a climbing hoist. Retrofitting is possible. Order all parts that are required for retrofitting from the manufacturer.

Tab. 1: Installation positions



Fig. 8: Standard position



Fig. 9: climbing hoist

⚠ CAUTION

chain jam

A chain jam in the chain guide causes damage to the hoist and chain.

- When operating the electric chain hoist, and especially when using it as a climbing hoist, the incoming and outgoing chain strands must always be kept taut.

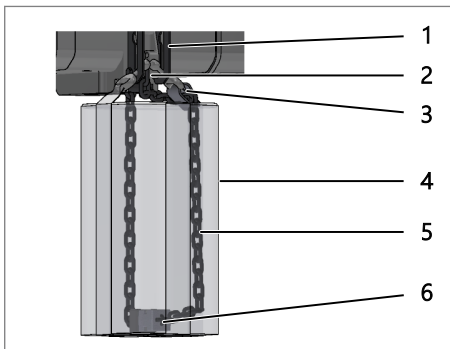

Fig. 10: Mounting the chain end

- 1 Retaining plates
- 2 Chain box screw
- 3 Chain box support
- 4 Chain box Flip bag
- 5 Free chain/chain end
- 6 Lift limiter

! NOTICE

Mounting the lift limiter

The chain end of the load chain is attached to the electric chain hoist. Guide the chain through the chain box support.

The lift limiter must be mounted in such a way that the lift limiter lies on the floor of the chain box.

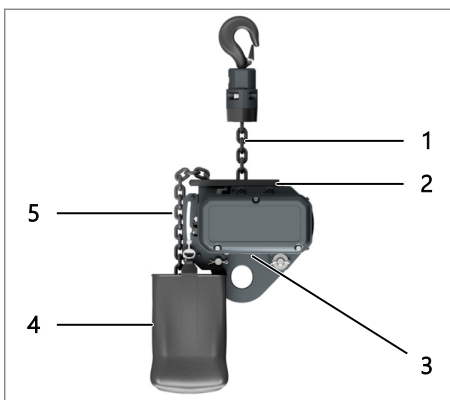

Fig. 11: Use in the climbing position

- 1 Load chain strand
- 2 Chain guide plate
- 3 Water drain hole
- 4 Chain box
- 5 Free chain strand

! NOTICE

When using the climbing hoist outdoors, protect the electric chain hoist from rainwater. Check the functionality of the water drain hole before use.



The chain box flip bag can be used in the standard and climbing positions.

Type plate

3.5 Arrangement of the load chain

Arrangement of the load chain

⚠ CAUTION
Risk of falling load
 Chain may break.

- Use only original chains from the manufacturer. These meet the high requirements regarding load capacity and service life.

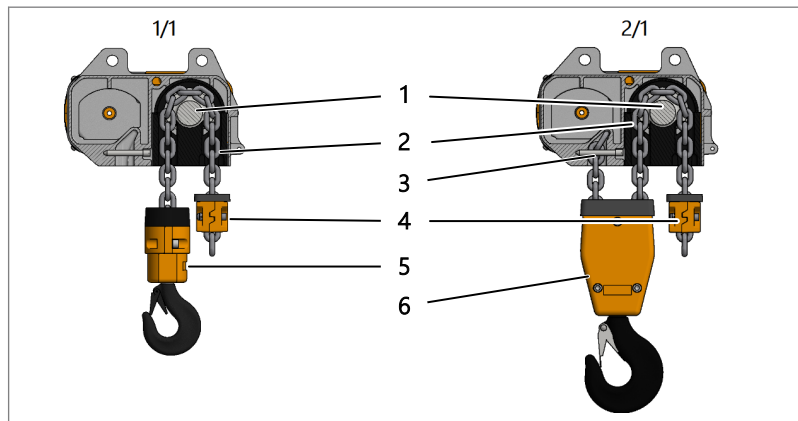

Fig. 12: Load chain arrangement

- 1 Pinion shaft chain sprocket
- 2 Load chain
- 3 Chain end fastener (chain clamp)
- 4 Lift limiter
- 5 Hook tackle
- 6 Hook block

i The single fall version has the identifier 1/1.
 The double fall version has the identifier 2/1.

3.6 Type plate

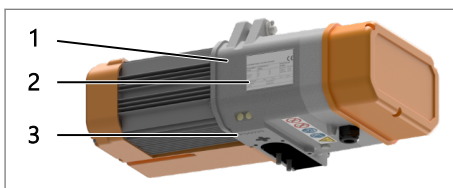

Fig. 13: Identification of the electric chain hoist

- 1 Electric chain hoist housing
- 2 Type plate
- 3 Stamped serial number

i **Serial number**
 The serial number of the electric chain hoist is stamped in the area of the chain outlet. This enables accurate identification of the electric chain hoist even if the type plate is not legible or missing.

1	ELEKTROKETTENZUG / ELECTRIC CHAIN HOIST			CE
2	Bauform/Model: 031/51 Fabrik-Nr./Serial no.: P00033 Baujahr/Fabr. year: 01/2024			
3	WLL (kg)	1/1: 250	2/1: 500	5,2x15 mm EN 818-7
4	(m/min)	8/2	4/1	FEM/ISO 3m/M6 50/25% ED 300 S/h
5	K-LORW 63GV8-2 400 V; 50 Hz; 3 ph F; IP 55			
	0,32/0,08 kW		cos φ 0,72/0,61	
	1,2/0,8 A		2730/640 min ⁻¹	

Fig. 14: Example type plate

- 1 Manufacturer
- 2 Machine type
- 3 Type; serial number; year of construction (mm/yyyy)
- 4 Technical data
- 5 Motor data

3.7 Explanation of type designation

6300	/	2	-	4	/	1
1		2		3		4

Fig. 15: Type designation

- Example for type 111/54:
- 1 Load capacity in kg
 - 2 Number of chain falls
 - 3 Speed of main hoist in m/min
 - 4 Speed of creep hoist in m/min

3.8 Conditions of use

	Area of application	Remarks
Operating temperature	-20 °C to +40 °C	Winding heater (optional)
Operating temperature	-40 °C to +40 °C	Applies only to electric chain hoists with chains in accordance with EN 818-7, T
Idling temperature	-30 °C to +50 °C	
Air humidity	Maximum 85 %	Temperature must not fall below dewpoint
Protection class	IP 55	See type plate
Insulation class	F (155 °C)	
Operating altitude	Max. 1000 m above sea level	

! NOTICE

In the case of different conditions of use and for use in aggressive media, please contact the manufacturer.

3.9 Electrical data

3.9.1 Lift motor

! NOTICE

The fuse before the main switch is to be provided by the operator via a slow fuse.

3-phase lifting devices

Tab. 2: Electrical data at 380–415 V / 50 Hz and 440–480 V / 60 Hz

Motor type	380–415 V / 50 Hz		440–480 V / 60 Hz		Mains fuse [A]	Mains cable A [mm ²]	L max. [m]
	P [kW]	I [A]	P [kW]	I [A]			
63G2	0.55	1.3	0.65	1.3	6	1.5	220
63G2	0.70	1.6	0.84	1.6	6	1.5	220
63G4	0.37	1.1	0.44	1.1	6	1.5	220
63GV8-2	0.32 0.08	1.2 0.8	0.38 0.10	1.3 0.8	6	1.5	220
71G2	1.1	2.8	1.3	2.4	6	1.5	220
71G4	0.75	1.9	0.90	1.9	6	1.5	220
80G2	1.5	2.9	1.8	2.9	6	1.5	130
80G2	1.7	3.4	2.1	3.4	6	1.5	130
80G8-2	0.90 0.20	2.0 1.6	1.1 0.24	2.4 2.0	6	1.5	220
80G8-2	1.1 0.23	2.5 1.7	1.3 0.27	2.5 1.7	6	1.5	220
80GZ8-2	2.1 0.50	4.8 3.2	2.5 0.60	4.8 3.3	10	1.5	130
90L2	3.0	5.9	3.6	5.9	16	1.5	80
90L4	2.2	4.8	2.6	4.8	16	1.5	130
90L8-2	1.8 0.45	4.3 2.0	2.16 0.54	4.2 2.6	10	1.5	130
100S2	4.0	10.7	4.8	10.7	20	1.5	50

Electrical data > Traversing motor

Motor type	380–415 V / 50 Hz		440–480 V / 60 Hz		Mains fuse [A]	Mains cable	
	P [kW]	I [A]	P [kW]	I [A]		A [mm ²]	L max. [m]
100L8-2	3.0 0.75	7.2 3.0	3.6 0.90	7.2 3.0	16	1.5	60
100LV8-2	4.4 1.1	10.5 4.2	5.2 1.3	10.6 4.2	20	1.5	50

Tab. 3: Electrical data at 220–240 V / 50 Hz and 250–275 V / 60 Hz

Motor type	220–240 V / 50 Hz		250–275 V / 60 Hz		Mains fuse [A]	Mains cable	
	P [kW]	I [A]	P [kW]	I [A]		A [mm ²]	L max. [m]
63G2	0.55	2.3	0.65	2.3	6	1.5	120
63G2	0.70	2.8	0.84	2.8	6	1.5	120
63G4	0.37	1.9			6	1.5	120
63GV8-2	0.32 0.08	2.1 1.4	0.38 0.10	2.2 1.4	6	1.5	120
71G2	1.1	4.1	1.3	4.1	10	1.5	70
71G4	0.75	3.4	0.90	3.3	6	1.5	120
80G2	1.5	5.0	1.8	5.1	16	1.5	70
80G2	1.7	5.9	2.1	5.9	16	1.5	70
80G8-2	0.9 0.20	3.4 2.8	1.1 0.24	3.5 3.0	10	1.5	70
80G8-2	1.1 0.23	4.3 2.9	1.3 0.27	4.3 3.0	10	1.5	70
80GZ8-2	2.1 0.50	8.3 5.6			20	1.5	30
90L2	3.0	10.2	3.6	10.2	25	1.5	25
90L4	2.2	8.3	2.6	8.2	20	1.5	25
90L8-2	1.8 0.45	7.5 3.4	2.16 0.54	7.3 4.5	20	1.5	40
100S2	4.0	18.5	4.8	18.5	32	1.5	30
100L8-2	3.0 0.75	12.4 5.1	3.6 0.90	12.4 5.2	25	1.5	25
100LV8-2	4.4 1.1	18.2 7.3	5.2 1.3	18.4 7.3	32	2.5	30

1-phase lifting devices

Tab. 4: Electrical data at 110 V / 50 Hz and 110 V / 60 Hz

Motor type	110 V / 50 Hz		110 V / 60 Hz		Mains fuse [A]	Mains cable	
	P [kW]	I [A]	P [kW]	I [A]		A [mm ²]	L max. [m]
63G2	0.35	6.1	0.35	5.6	16	2.5	80
80G2	1.1	19	1.1	18.0	32	2.5	130
80G2			1.3	22.0	32	2.5	130

Tab. 5: Electrical data at 230 V / 50 Hz and 230 V / 60 Hz

Motor type	230 V / 50 Hz		230 V / 60 Hz		Mains fuse [A]	Mains cable	
	P [kW]	I [A]	P [kW]	I [A]		A [mm ²]	L max. [m]
63G2	0.35	3.2	0.35	3.2	10	2.5	70
71G2	0.55	4.7	0.55	4.3	10	2.5	70
71G2	0.7	5.6	0.7	5.4	16	2.5	70
80G2	1.1	9.1	1.1	8.2	20	2.5	30
80G2			1.3	10.0	20	2.5	30

3.9.2 Traversing motor

The trolley type and traversing speeds are indicated on the trolley type plate.

Tab. 6: Electrical data of the trolley at 380–415 V / 50 Hz and 440–480 V / 60 Hz

Motor type	380–415 V / 50 Hz		440–480 V / 60 Hz		Mains fuse [A]	Mains cable	
	P [kW]	I [A]	P [kW]	I [A]		A [mm ²]	L max. [m]
56 G6	0.12	0.59	0.14	0.62	See lifting device	See lifting device	See lifting device
56 K4	0.12	0.44	0.14	0.48			
63 GV 8-2	0.18/0.04	0.77/0.56	0.18/0.04	0.78/0.59			
4KD71B4x 8-2	0.18/0.04	0.55/0.35	0.22/0.05	0.55/0.35			
4KD71C4x 8-2	0.25/0.06	0.65/0.55	0.3/0.07	0.65/0.55			
4KD80E4x 8-2	0.55/0.12	1.3/0.85	0.55/0.12	1.3/0.85			

Tab. 7: Electrical data of the trolley at 220–240 V / 50 Hz and 250–275 V / 60 Hz

Motor type	220–240 V / 50 Hz		250–275 V / 60 Hz		Mains fuse [A]	Mains cable	
	P [kW]	I [A]	P [kW]	I [A]		A [mm ²]	L max. [m]
56 G6	0.12	1.03	0.14	1.08	See lifting device	See lifting device	See lifting device
56 K4	0.12	0.77	0.14	0.84			
63 GV 8-2	0.18/0.04	1.35/0.97	0.18/0.04	1.35/1.0			
4KD71B4x 8-2	0.18/0.04	0.83/0.54	Unavailable	Unavailable			
4KD71C4x 8-2	Unavailable	Unavailable	Unavailable	Unavailable			
4KD80E4x 8-2	Unavailable	Unavailable	Unavailable	Unavailable			

3.10 Main dimensions

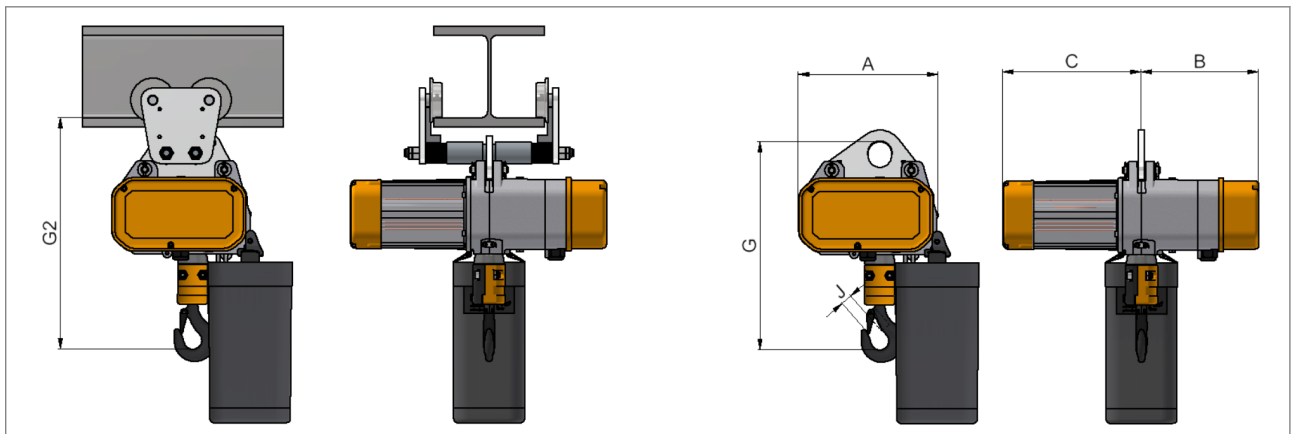

Fig. 16: Main dimensions

Tab. 8: Main dimensions

Type	Load chain	Chain weight	Motor	Weight ¹⁾	Dimensions							Hook size	
					A	B ²⁾	C	G	G2	ØN	J		
	[mm]	[kg/m]		[kg]	[mm]	[mm]	[mm]	[mm]	[mm]	[mm]	[mm]	[mm]	DIN 15401
030/...	1/1 5.2x15	0.59	63G2 63G4 63K2	18	212	192	220	365	409	37	20	012	
030/...	2/1 5.2x15	0.59	63G2 63G4 63K2	18	212	192	220	413	454	37	22	025	
031/...	1/1 5.2x15	0.59	63GV8-2	18	212	192	220	365	409	37	20	012	
031/...	2/1 5.2x15	0.59	63GV8-2	21	212	192	220	413	454	37	22	025	

¹⁾ Lifting height = 3 m; single-hole suspension lug

²⁾ Dimension B is larger in the version with a gear limit switch.

Noise level

Type		Load chain [mm]	Chain weight [kg/m]	Motor	Weight ¹⁾ [kg]	Dimensions							Hook size DIN 15401
						A [mm]	B ²⁾ [mm]	C [mm]	G [mm]	G2 [mm]	ØN [mm]	J [mm]	
050/...	1/1	5.2x15	0.59	71G2 71G4 80G2	33 33 38	266	232	274	388	460	37	20	012
050/...	2/1	5.2x15	0.59	71G2 71G4 80G2	33 33 38	266	232	274	388	460	37	22	025
051/...	1/1	5.2x15	0.59	80G8-2 80GZ8-2	33 39	266	232	274	388	460	37	20	012
051/...	2/1	5.2x15	0.59	80G8-2 80GZ8-2	31 40	266	232	274	436	460	37	20	025
070/...	1/1	7.2x21	1.13	71G2 71G4 80G2 80K4	36 36 42 42	266	232	274	413	460	47	22	025
070/...	2/1	7.2x21	1.13	71G2 71G4 80G2 80K4	41 41 47 47	266	232	274	514	561	47	28	05
071/...	1/1	7.2x21	1.13	80G8-2 80GZ8-2	38 47	266	232	274	413	460	47	22	025
071/...	2/1	7.2x21	1.13	80G8-2 80GZ8-2	41 53	266	232	274	514	561	47	28	05
090/...	1/1	9x27	1.8	90L2 90L4 100S2	69 69 79	357	283	359	513	548	58	28	05
090/...	2/1	9x27	1.8	90L2 90L4 100S2	78 78 88	357	283	359	620	655	58	30	1
091/...	1/1	9x27	1.8	90L8-2 100LV8-2	67 88	357	283	359	513	548	58	28	05
091/...	2/1	9x27	1.8	90L8-2 100LV8-2	76 97	357	283	359 406	620	655	58	30	1
097/...	1/1	7.2x21	1.13	100L8-2 100LV8-2	67 88	357	283	359 406	590	625	58	28	05
110/...	1/1	11.3x31	2.85	90L4 100S2	93 96	357	291	367	611	678	67	30	1
110/...	2/1	11.3x31	2.85	90L4 100S2	92 102	357	291	367	740	807	67	42	2.5
111/...	1/1	11.3x31	2.85	100L8-2 100LV8-2	96 118	357	291	367 410	611	678	67	30	1
111/...	2/1	11.3x31	2.85	100L8-2 100LV8-2	113 135	357	291	367 410	740	807	67	42	2.5

1) Lifting height = 3 m; single-hole suspension lug

2) Dimension B is larger in the version with a gear limit switch.

3.11 Noise level

The sound pressure level of the electric chain hoists is determined during lifting and lowering with full load at a distance of 1 m from the electric chain hoist. Depending on the type, it is 70–77 dB(A). The exact value is entered in the test book.

4 Assembly instructions

4.1 Scope of delivery, transport and storage

4.1.1 Scope of delivery

NOTICE

After delivery, the goods must be checked for transport damage and completeness including documentation.

The scope of delivery may differ from the information in this document in cases of special versions, technical changes and additional ordering options.

4.1.2 Transport

NOTICE

Transport work may only be carried out by qualified personnel.

The manufacturer assumes no liability for damages resulting from improper transport and storage.

The hoists and accessories are checked and properly packed before delivery.

CAUTION

The hoists must not be transported on damaged pallets.

The hoists must not be thrown or overturned.

Transport with damaged transport safety devices is prohibited.

The hoists must not be exposed to rain or moisture.

4.1.3 Storage

The hoists must be stored dry and clean under the following conditions:

- Storage in buildings
- Storage temperature range -20 °C to +40 °C
- No high temperature differences, no corrosive environment
- Maximum humidity 85%
- Store dry and free from dust
- No aggressive environment
- No direct sunlight
- Lubricate bare components (rust protection)

4.2 Requirements

4.2.1 Safety instructions for assembly

DANGER

Live parts

There is danger to life and limb.

- Work on electrical equipment may only be carried out by qualified electricians.
- Before starting work, switch off the electrical power supply and secure it against unauthorised reactivation.

 **WARNING**

Improper assembly

There is danger to life and limb.

- Installation work on hoists may only be carried out by authorised and instructed personnel.
- Before starting work, make sufficient room to carry out assembly.
- Cordon off the working and hazard area.
- Wear protective equipment.
- Carry out the assembly and installation work only with suitable and tested tools and aids.
- Assemble components properly. Adhere to screw tightening torques.

 **CAUTION**

Sharp-edged components

There is a risk of injury.

- Wear protective equipment.

 **NOTICE**

The voltage and frequency of the power supply must match the information on the type plate of the hoist and its attachment parts.

The required power supply depends on the size of the motor of the hoist.

 **NOTICE**

Main switch

A main switch must be provided to disconnect all poles of the power supply from the mains. The main switch must be easily accessible and labelled.

 **NOTICE**

Circuit breaker

If several hoists are fed from one main power supply, each hoist must have its own circuit breaker.

 **WARNING**

Use only original parts from the manufacturer.

4.2.2 Qualification of the assembler

Assembly work may only be carried out by competent persons at the instructions of the operator. The persons must be familiar with the function and operation of the hoist and its attachment parts.



Electrical work may only be carried out by qualified specialists in compliance with all safety regulations.

4.2.3 Unpacking the goods

 **NOTICE**

The goods must be unpacked on a stable surface or on work surfaces.

Use suitable aids to lift large loads.

1.  Remove the hoist and components from the packaging.
2.  Place them gently on the work surface.

3. → Have the operating instructions ready at hand.
4. → Separate the packaging materials according to type and size and dispose of them in an environmentally friendly manner.

4.2.4 Inspection before assembly

1. → Check the goods for visible damage.
2. → Check the completeness of the delivery.
3. → Compare load specifications on the type plate and lifting gear (load hooks, suspension lugs, suspension hook, trolley, etc.).
 - ➔ The information must match.

! NOTICE

Prior to assembly, it must be checked whether the support structure is designed to accommodate the hoist and its attachment parts, including the maximum load.

4.3 Lifting gear

All lifting gear comes pre-attached as standard. In the case of deliveries without a chain, the chain must be fitted and the corresponding lifting gear must be correctly attached. Only chains from the manufacturer of the electric chain hoist may be used. Assembly must be carried out by a qualified person.

4.3.1 Hook tackle

i The hook tackle is the load attachment device for single fall hoists.

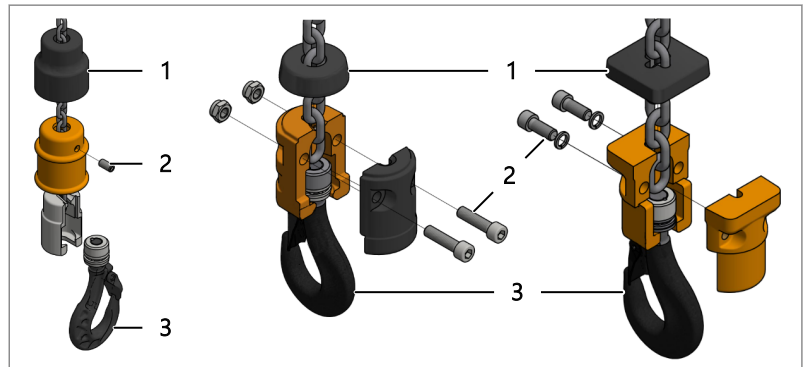

Fig. 17: Hook tackle

- 1 Rubber buffer
- 2 Connectors
- 3 Complete load hook (including thrust bearing)

Assembling the hook tackle

1. → Thread the rubber buffer (and securing sleeve) onto the chain.
2. → Insert the chain end into the hook bowl.
3. → Insert the load hook into the hook bowl.
4. → Close the cover of the hook bowl or push the securing sleeve over the housing.
5. → Attach the connectors.
6. → Push the rubber buffer up to the hook tackle.

Tab. 9: Tightening torques of the screw connections

Chain size [mm]	WLL [kg]	Screw size	Quantity	Torque [Nm]
5.2x15 5x15	500	M8x16 threaded pin DIN EN ISO 4026	1	- Screwed in flush
7.2x21 7x22	1000	M10x40 DIN EN ISO 4762	2	35
9x27	1600	M12x30 DIN EN ISO 4762	2	50
11.3x31	3200	M12x35 DIN EN ISO 4762	2	50

Spring trigger

The spring trigger triggers the limit switch for the lifting or lowering movement and allows a sufficiently large braking distance.

! NOTICE

Use of spring triggers

Spring triggers are used for lifting speeds greater than or equal to 15 m/min.

i *Electric chain hoists with a gear limit switch or without a limit switch are not fitted with spring triggers.*

Electric chain hoists with hook block are not equipped with spring triggers.

4.3.2 Hook block

i *The hook block is the load attachment device for hoists in the double fall version.*

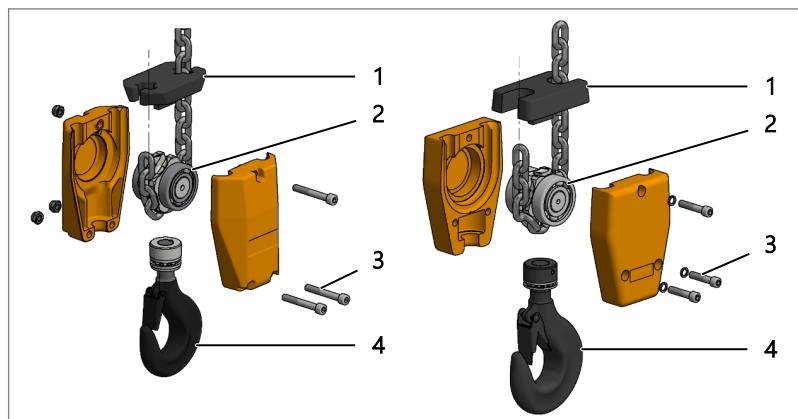

Fig. 18: Hook block

- 1 Rubber buffer
- 2 Chain sprocket
- 3 Connectors
- 4 Complete load hook (including thrust bearing)

Assembling the hook block

1. → Thread the rubber buffer onto the chain.
2. → Lay the chain around the chain sprocket.

3. → Place the chain sprocket with chain in one half of the housing.

! NOTICE

The chain must not be twisted.

4. → Thread the chain end through the rubber buffer.
 - ▶ The rubber buffer must be in contact with the housing.
5. → Insert the load hook into the housing.
6. → Seal with the second half of the housing.
7. → Attach the connectors.
8. → Check that the rubber buffer is firmly attached to the hook block.

Tab. 10: Tightening torques of the screw connections

Chain size [mm]	WLL [kg]	Screw size	Quantity	Torque [Nm]
5.2x15 5x15	1000	M6×40 DIN EN ISO 4762	2/1	10/6
7.2x21 7x22	2000	M8×50 DIN EN ISO 4762	2/1	20/10
9x27	3200	M10×50 DIN EN ISO 4762	2/1	35
11.3x31	6300	M12×60 DIN EN ISO 4762	3	35

4.3.3 Load chain

Requirements for assembly

Assembling the load chain

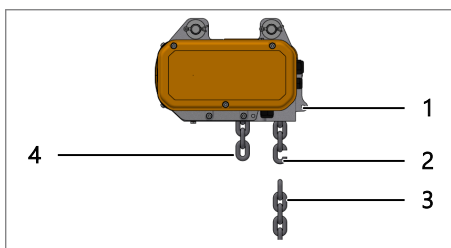

Fig. 19: Connecting the load chain

- Chain hoist properly fitted.
- Assembly chain from manufacturer attached.
- Load chain and connecting link ready.

- 1 Chain box side
- 2 Connecting link
- 3 Load chain
- 4 Assembly chain

1. → Insert the connecting link into the assembly chain on the chain box side.

! NOTICE

The opening of the connecting link should be facing outwards.

2. → Connect the load chain with the connecting link.
3. → Press the Lower button.
Let the chain be guided into the housing until approx. 0.5 m of the chain remains on the load side.

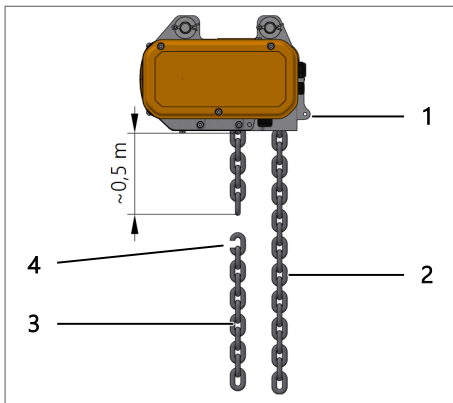

Fig. 20: Removing the assembly chain

Version 1/1

Version 2/1

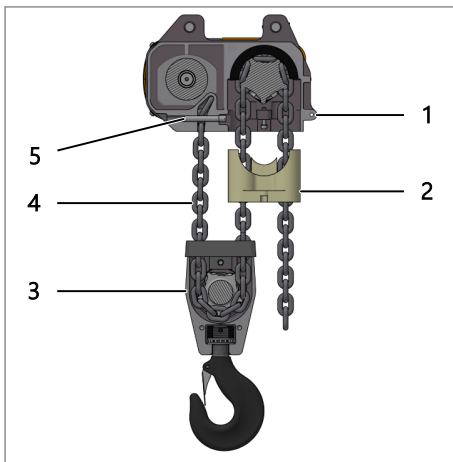

Fig. 21: Assembling the 2/1 chain

- 1 Chain box side
- 2 Load chain
- 3 Assembly chain
- 4 Connecting link

4. → Remove the assembly chain and connecting link.

5. → Assembling the hook tackle.

➔ Continue with point 11

- 1 Chain box side
- 2 Chain guide
- 3 Hook block
- 4 Load chain
- 5 Chain clamp

6. → Pull the chain through the hook block using a tightening wire.

➔ The chain must not be twisted between the chain guide and the hook block.

7. → Release the chain guide.

8. → Insert the chain into the housing through the cross-shaped opening until the first chain link protrudes inside the housing.

9. → Hold the chain in this position with one hand and push the chain clamp into the two holes with the other hand.

➔ Check for tight fit by pulling on the chain sharply.

10. → Reattach the chain guide.

! NOTICE

Chain sizes 9x27 and 11.3x31:

- Insert the chain guide fastening screws with the thread-locking paste. The threads must be free of oil and grease.

Tab. 11: Recommended thread-locking pastes

Manufacturer	Name	Properties
Weicon®	Weiconlock AN 302-42	Thread-locking paste, suitable for connections up to M36, breakaway torque min. 14 to 18 Nm
Henkel®	Loctite 243	Thread-locking paste, suitable for connections up to M20, breakaway torque min. 20 Nm

! CAUTION

Risk of falling load

Check again:

- The chain must not be twisted between the chain guide and the hook block.

If assembly without a twisted chain is not possible, shorten the chain by one link!

11. → Fit the lift limiter at the chain end on the chain box side.

! NOTICE

Load chain running out from the chain box

- Standard: fit the lift limiter to the third link before the chain end.
- Special version: The chain end of the load chain is attached to the electric chain hoist. The lift limiter must be mounted in such a way that the lift limiter lies on the floor of the chain box.

12. → Insert the lift limiter into the chain box.

13. → Attach the chain box.

14. → Press the Lift button and allow the chain to go into the chain box.



At the same time, lubricate the free end of the chain as it enters the chain box.

Lift limiter

The lift limiter prevents the free end of the chain from running out of the electric chain hoist.

In the version with operational limit switches, the lift limiter acts as a trigger.

In the event that an operational limit switch fails, the lift limiter in conjunction with the slip clutch provides protection against overloading.

! CAUTION

Electric chain hoist without electric limit switches or gear limit switches

In the case of electric chain hoists without electric limit switches or gear limit switches, the lift limiter must not run against the housing during operation.

Assembling the lift limiter

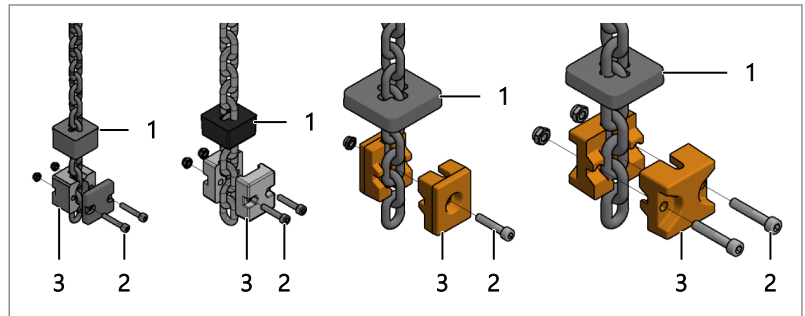

Fig. 22: Lift limiter assembly

- 1 Rubber buffer
- 2 Connectors
- 3 Lift limiter body

1. → Thread the rubber buffer to the end of the free chain strand.

! NOTICE

In the case of the rubber buffer with the vulcanised disc, the disc must be directed towards the housing of the electric chain hoist.

2. → Insert the chain into the lift limiter half.

! NOTICE

Load chain running out from the chain box

- Standard: fit the lift limiter to the third link before the chain end.
- Special version: The chain end of the load chain is attached to the electric chain hoist. The lift limiter must be mounted in such a way that the lift limiter lies on the floor of the chain box.

3. → Cover with the other half of the lift limiter.

4. → Attach the connectors.

5. → Push the rubber buffer up to the lift limiter.



If the lift limiter is mounted 50 cm before the chain end, the additional chain length must be taken into account when ordering.

Tab. 12: Tightening torques of the screw connections

Chain size	Load capacity	Screw size	Quantity	Torque
[mm]	[kg]			[Nm]
5.2x15 5x15	1000	M5x30 DIN EN ISO 4762	2	4
7.2x21 7x22	2000	M6x30 DIN EN ISO 4762	2	7
9x27	3200	M8x40 DIN EN ISO 4762	1	18
11.3x31	6300	M10x55 DIN EN ISO 4762	2	35

Assembling the lift limiter with spring trigger

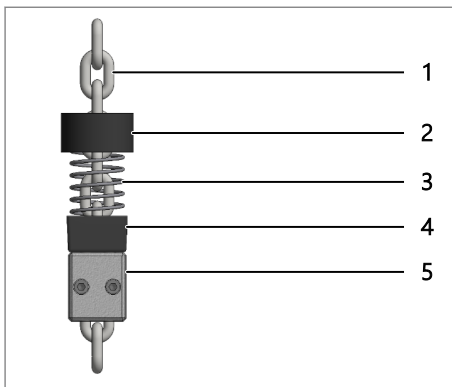

Fig. 23: Lift limiter with spring trigger

- 1 Load chain
- 2 Pressure piece
- 3 Pressure spring
- 4 Rubber buffer
- 5 Lift limiter

1. → Thread the spring trigger (pressure piece and pressure spring) onto the load chain.

2. → Thread the rubber buffer onto the chain.

3. → Insert the chain end into one half of the housing of the lift limiter.

! NOTICE

Load chain running out from the chain box

- Standard: fit the lift limiter to the third link before the chain end.
- Special version: The chain end of the load chain is attached to the electric chain hoist. The lift limiter must be mounted in such a way that the lift limiter lies on the floor of the chain box.

4. → Cover with the other half of the lift limiter housing.

5. → Attach the connectors.

6. → Slide the rubber buffer up to the lift limiter.

7. → Slide the spring trigger up to the rubber buffer.

4.4 Chain box

4.4.1 Chain box assembly information

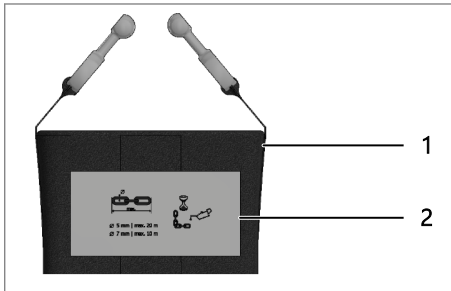

Fig. 24: Identification (example)

- 1 Chain box
- 2 Label with chain dimension and maximum permitted chain length

Before assembly, check that the chain dimensions and maximum chain length match the specifications on the chain box.



For double fall electric chain hoists, note that the chain length = 2x lifting height.

CAUTION

Do **not** continue assembly, if:

- The chain length is greater than the one specified on the chain box.
- The marking on the chain box is missing or unreadable.

WARNING

Injury to persons and damage to property

- Do not overload the chain box.
- Use the chain box securing nut only once.

CAUTION

Risk of load chain becoming knotted

- Only allow the chain to run in with motor force. Do **not** insert it into the chain box by hand.
- Lubricate the chain.

CAUTION

Risk of crushing

Risk of body parts being crushed or clothes and hair becoming caught.

- Do not touch the chain when it is moving.
- Do not reach into the chain inlets.

4.4.2 Chain box Flip bag

Assembly

Requirements for assembling the Flip bag – chain box:

- The length of free chain hanging from the housing should be approx. 0.5 m.
- Lift limiter and spring trigger (option).

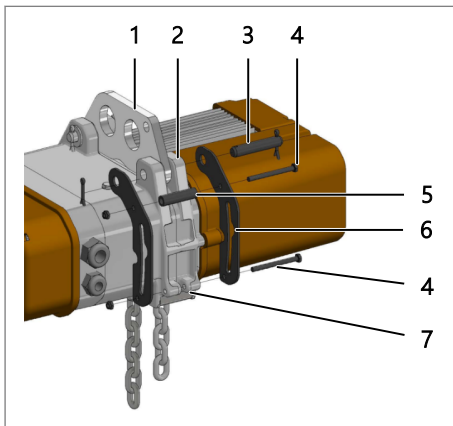

Fig. 25: Mounting the retaining plates

- 1 Suspension (variable)
- 2 Housing suspension point
- 3 Suspension bolt with splints
- 4 Screw and securing nut
- 5 Spacer sleeve(s)
- 6 Retaining plates
- 7 Suspension point of the chain box

1. → Fit the retaining plates with bolts and splints together with the suspension to the suspension point of the housing.

! NOTICE

The washers on the suspension bolt are not required.

2. → Fit the retaining plates to the protrusions of the chain box suspension using the screw and securing nut.
3. → Fit the spacer sleeve(s) with the screw and securing nut.
4. → Loosely insert the chain end with the fitted lift limiter into the chain box.

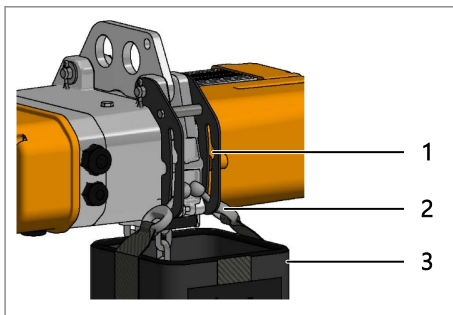

Fig. 26: Connecting the chain box

- 1 Opening in retaining plate
- 2 Chain box support
- 3 Chain box

5. → Connect the chain box support to the openings in the retaining plates.
6. → Press the Lift button. Allow the chain to go into the chain box.



At the same time, lubricate the free end of the chain as it enters the chain box.

4.4.3 Fabric chain box

Assembly

Requirements for assembling the chain box:

- Chain hoist properly fitted.
- The length of free chain hanging from the housing should be approx. 0.5 m.
- Lift limiter and spring trigger (option).

1. → Loosely insert the chain end with the fitted lift limiter into the chain box.

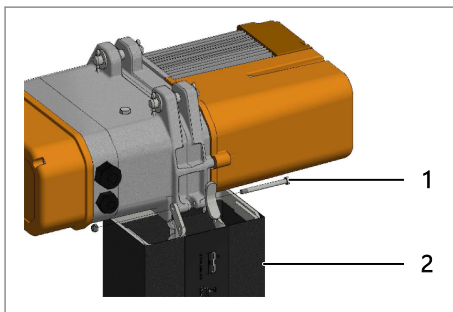
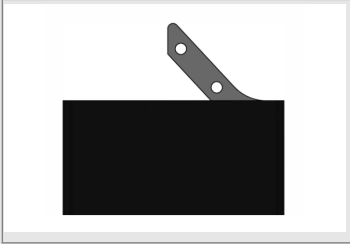



Fig. 27: Assembling the chain box

- 1 Screw and securing nut
- 2 Chain box

2. → Fit the chain box with the screw and securing nut.

Type A chain box	Type B chain box
	
Chain box with flat steel frame	Chain box with round steel frame
Do not overtighten the screw. Only tighten the securing nut until firmly attached. The chain box must be freely movable.	Screw connection tightening torque: 10 Nm

- Press the Lift button. Allow the chain to go into the chain box.

 *At the same time, lubricate the free end of the chain as it enters the chain box.*

Oversized chain box

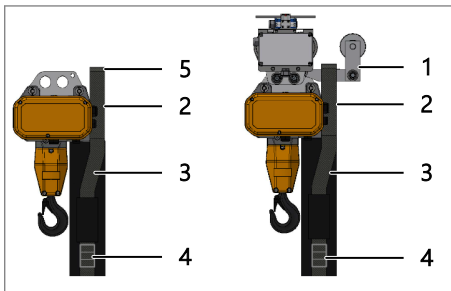

Fig. 28: Stationary suspension with trailing trolley

! NOTICE

From a chain weight of 25 kg, fabric chain boxes must be relieved of load by means of a belt strap.

- Trailing trolley
- Edge protector
- Belt strap
- Ratchet
- Suspension point (customer provided)

Stationary electric chain hoists must have a customer-provided suspension point for strain relief. Electric chain hoists with a trolley require a trailing trolley to which the harness is fastened.

- Loosely insert the chain end with the fitted lift limiter into the chain box.
- Fit the chain box with the screw and securing nut.

! NOTICE

Do not overtighten the screw. Only tighten the securing nut until firmly attached.

The chain box must be freely movable.

- Press the Lift button. Allow the chain to go into the chain box up to a filling height of 15 cm.
- Align the belt strap and edge protector.
- Tighten the belt strap with a ratchet.
- Allow the chain to run in completely.

 *At the same time, lubricate the free end of the chain as it enters the chain box.*

Stationary suspension

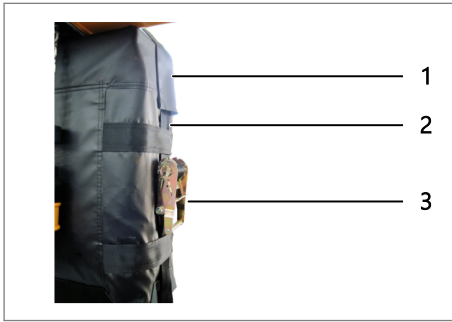

Fig. 29: Chain box relief

- 1 Edge protector
- 2 Belt strap
- 3 Ratchet

7. → Check the belt strap and edge protector again for correct seating and tension.

CAUTION

Trailing trolleys are not suitable for cornering and for mounting on single-bolt trolleys.

4.4.4 Sheet steel chain box

Assembly

Requirements for assembling the chain box:

- Chain hoist properly fitted.
- The length of free chain hanging from the housing should be approx. 0.5 m.
- Lift limiter and spring trigger (option).

1. → Loosely insert the chain end with the fitted lift limiter into the chain box.

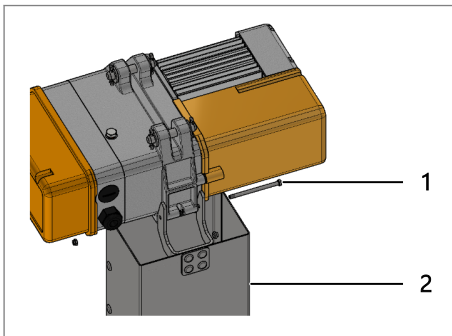

Fig. 30: Assembling the chain box

- 1 Screw and securing nut
- 2 Chain box

2. → Fit the chain box with the screw and securing nut.

NOTICE

Do not overtighten the screw. Only tighten the securing nut until firmly attached.

The chain box must be freely movable.

Supporting chain

3. → If the chain box is supplied with a supporting chain, the customer must fit this chain to relieve the load on the chain box.

Short supporting chains are attached to the chain box screw. The customer is responsible for attaching long supporting chains either to the trailing trolley or, in the case of electric chain hoists without a trolley, to a supporting structure.

4. → Press the Lift button. Allow the chain to go into the chain box.

i At the same time, lubricate the free end of the chain as it enters the chain box.

4.5 Stationary suspension

WARNING

Falling of the hoist

Serious injuries and damage to property are possible if the hoist falls.

- Use only the original fastening bolts of the manufacturer.

The use of screws to connect the electric chain hoist to the suspensions is prohibited!

4.5.1 Suspension hook

Arrangement

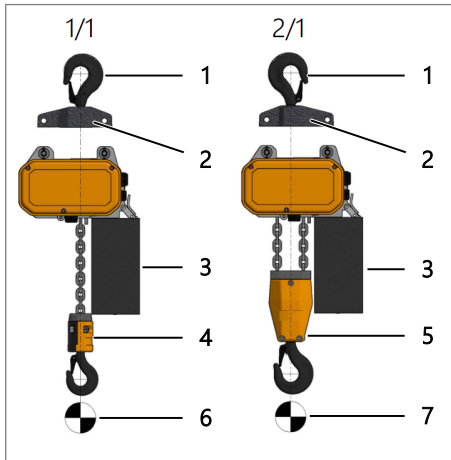

Fig. 31: Load centre arrangement

- 1 Suspension hook
- 2 Marking
- 3 Chain box
- 4 Hook tackle
- 5 Hook block
- 6 Load centre for 1/1 reeving
- 7 Load centre for 2/1 reeving

! CAUTION

Load centre

The suspension hook must be arranged so that the load centre is aligned with the seat of the suspension hook.

! NOTICE

For single fall operation, the marking for the 1/1 reeving must face the chain box side.

For double fall operation, the marking for the 2/1 reeving must face the chain box side.

Assembling the suspension hook

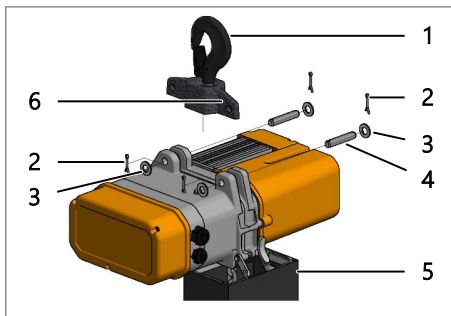

Fig. 32: Suspension hook assembly

- 1 Suspension hook
- 2 Splints
- 3 Washers
- 4 Bolts
- 5 Chain box
- 6 Marking

1. → Push the suspension hook between the suspension protrusions.

! NOTICE

The marking for the chosen reeving must be on the chain box side.

2. → Push the bolts through the suspension holes.
3. → Secure the bolts on both sides with washers and splints.

4.5.2 Single-hole suspension lug

Arrangement

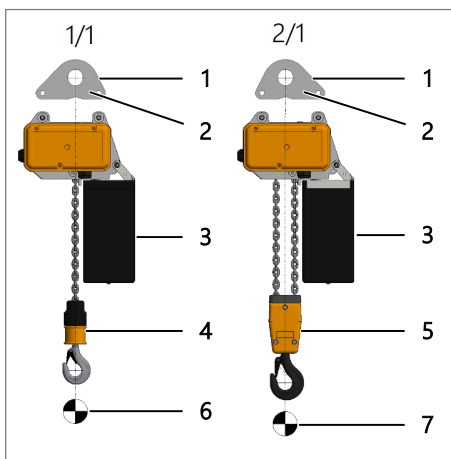

Fig. 33: Load centre arrangement

- 1 Single-hole suspension lug
- 2 Marking
- 3 Chain box
- 4 Hook tackle
- 5 Hook block
- 6 Load centre for 1/1 reeving
- 7 Load centre for 2/1 reeving

! CAUTION

Load centre

The single-hole suspension lug must be arranged so that the load centre is aligned with the locating hole of the single-hole suspension lug.

! NOTICE

For single fall operation, the marking for the 1/1 reeving must face the chain box side.

For double fall operation, the marking for the 2/1 reeving must face the chain box side.

Suspension with trolley

Assembling the single-hole suspension lug

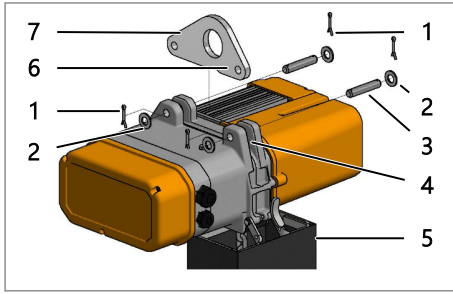

Fig. 34: Single-hole suspension lug assembly

- 1 Splints
- 2 Washers
- 3 Bolts
- 4 Suspension points on the housing
- 5 Chain box
- 6 Marking
- 7 Single-hole suspension lug

1. → Push the single-hole suspension lug between the suspension protrusions.

! NOTICE

The marking for the chosen reeving must be on the chain box side.

2. → Push the bolts through the suspension holes.

3. → Secure the bolts on both sides with washers and splints.

4.5.3 Suspension lug

Assembling the suspension lug

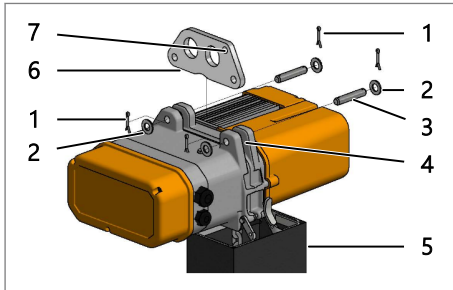

Fig. 35: Suspension lug assembly

- 1 Splints
- 2 Washers
- 3 Bolts
- 4 Housing suspension points
- 5 Chain box
- 6 Suspension lug
- 7 Hole for trailing trolley

1. → Push the suspension lug between the suspension protrusions.

! NOTICE

The hole for the trailing trolley shall be located on the chain box side.

2. → Push the bolts through the suspension holes.

3. → Secure the bolts on both sides with washers and splints.

4.6 Suspension with trolley

General information

The trolleys are suitable for

- Narrow I-beams acc. to DIN 1025 and Euronorm 24-62
- Medium-width I-beams acc. to DIN 1025
- Wide I-beams acc. to DIN 1025 (on request)

! NOTICE

For all other types of beams, inform the manufacturer about the flange width and flange thickness. The manufacturer will then select the appropriate trolley.

! WARNING

The operator must attach track limits to all track ends.

The track limits must have elastic buffers at the centre height of the rollers.

i *Electric travel limit switch option*

In addition, it is possible to fit the system with an electric travel limit switch. The trigger elements on the beam must be installed by the customer.

Structural engineering

Crane runways must be designed in accordance with DIN EN1999-1-3 and/or DIN EN 1993-6.

Older crane runways must be checked for state of the art.

In Germany, the crane runways must comply with the respective regional building regulations (LBO) of the federal state in which they are located.

The requirement for crane operation is an inspection of crane runways or crane track structures according to the requirements of VDI 6200.

The bending load of the trolley beam must be proven by the operator.

CAUTION

Bottom flange stress

The bottom flange stress must also be checked by a structural engineer according to FEM 9.341.

4.6.1 Trolley types

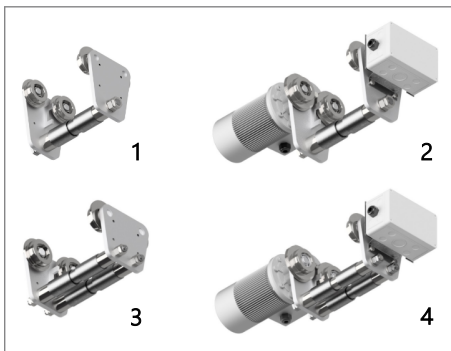

Fig. 36: Trolley types

- 1 Single-bolt manual trolley
- 2 Single-bolt electric trolley
- 3 Manual trolley
- 4 Electric trolley

4.6.2 Type designation

EFW	6300	N	5 + 20
1	2	3	4

Fig. 37: Type designation

- 1 Trolley type
- 2 Maximum load capacity in kg
- 3 Range of flange width N, S1 or S2
- 4 Electric trolley travel speeds in m/min

Abbreviation	Trolley type
EFW	Electric trolley
HFW	Manual trolley
EEFW	Single-bolt electric trolley
EHFW	Single-bolt manual trolley

4.6.3 Curve radii

Trolleys up to 6300 kg load capacity are suitable for cornering.

NOTICE

Cornering

Trolleys intended for use in cornering must not have a trailing trolley.

Tab. 13: Electric trolley curve radii

Trolley type	WLL	Min. curve radius
	[kg]	[m]
EFW 500	500	1.0
EFW 2000	2000	1.0

Trolley type	WLL	Min. curve radius
	[kg]	[m]
EFW 3200	3200	1.5
EFW 6300	6300	2.0

Tab. 14: Single-bolt electric trolley curve radii

Trolley type	WLL	Min. curve radius
	[kg]	[m]
EEFW 1000	1000	1.0
EEFW 2000	2000	1.0
EEFW 3200	3200	1.5
EEFW 6300	6300	2.0



Trolley motor arrangement

The trolley motor must always be mounted on the outside of the bend when cornering.

4.6.4 Arrangement

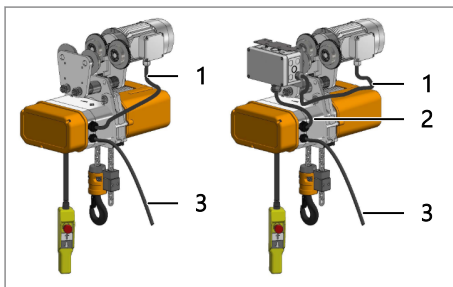

Fig. 38: Arrangement

- 1 Cable to the trolley motor
- 2 Trolley contactor control cable
- 3 Power supply

4.6.5 Assembling the trolley

Setting the width

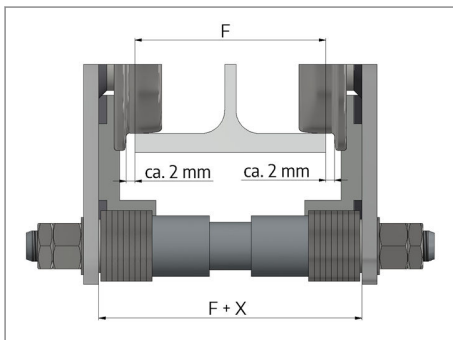

Fig. 39: Trolley setting width

! NOTICE

The distance between the wheel flange of the rollers and the beam flange must be about 2 mm.

The suspension lug is arranged between the spacer sleeves.

The spacer discs must be put in symmetrically.

Tab. 15: Trolley setting width

Trolley type	WLL	Dimension X
	[kg]	[mm]
EFW/HFW 500	500	31–33
EFW/HFW 2000	2000	31–33
EFW/HFW 3200	3200	32–34
EFW/HFW 6300	6300	42–44

Tab. 16: Setting width for single-bolt trolley

Trolley type	WLL	Dimension X
	[kg]	[mm]
EEFW/EHFW 1000	1000	31–33
EEFW/EHFW 2000	2000	31–33
EEFW/EHFW 3200	3200	32–34

Trolley type	WLL	Dimension X
	[kg]	[mm]
EEFW/EHFW 6300	6300	42-44

Tab. 17: Tightening torques

Nuts	Tightening torque
	[Nm]
M16x1.5	75
M22x1.5	150
M36x1.5	225

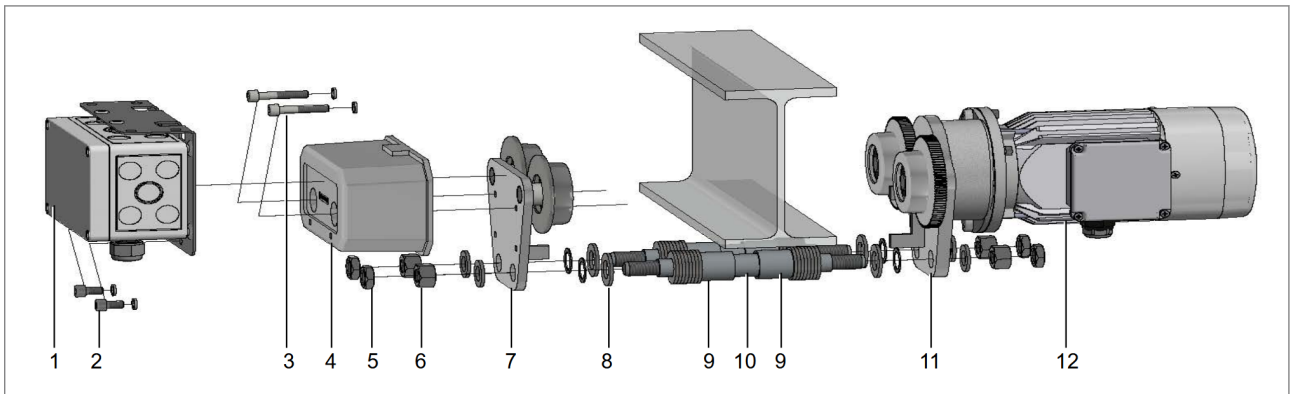

Fig. 40: Trolley exploded view

- | | |
|--|--|
| 1 Contactor control | 8 Spacer discs |
| 2 Fastening screws for contactor control | 9 Spacer sleeves |
| 3 Fastening screws for counterweight | 10 Suspension bolt |
| 4 Counterweight | 11 Side panel (powered side panel in the case of electric trolley) |
| 5 Lock nuts | 12 Travel motor (for electric trolley) |
| 6 Nuts and washers | |
| 7 Side panel (not powered) | |

Assembling the trolley

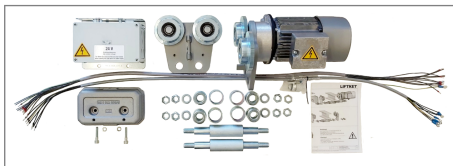

Fig. 41: Example of trolley parts



Fig. 42: Measuring flange width

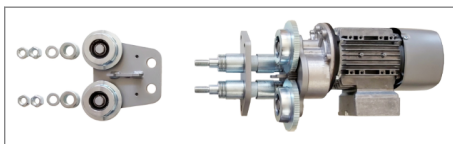

Fig. 43: Installation of side panel

1. See the exploded-view drawing for orientation.
2. Lay out all trolley parts for assembly on a secure work surface.

3. Measure the flange width.
4. Determine the number of spacer discs required to achieve the required clearance between the side panels.

5. Fit the suspension bolt with spacer discs, washers and nuts to the first side panel.



For electric trolleys, start with the motor side panel.

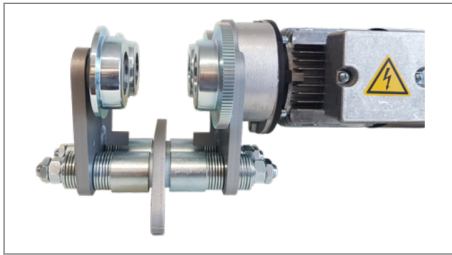

Fig. 44: Spacer sleeves and discs

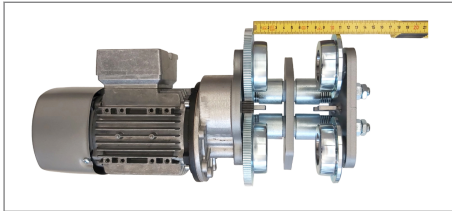

Fig. 45: Checking the setting width

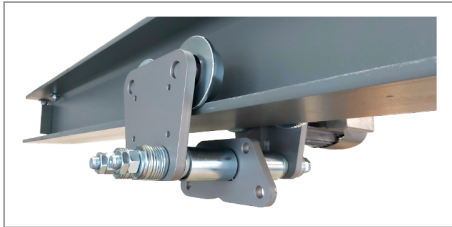

Fig. 46: Assembly on the beam

6. → Slide the suspension lug between the spacer sleeves onto the suspension bolt.

i *The spacer discs must be distributed symmetrically.
Below the maximum possible setting width, discs must be positioned outside the side panels.*

7. → Insert the second side panel onto the suspension bolt.
8. → Secure the side panel with washers, nuts and lock nuts.
9. → Check the setting width.

10. → Fit the trolley onto the beam.
11. → Tighten the nuts using the torque wrench.
→ *Tab. 17 'Tightening torques' on page 39*
12. → Secure the nuts with lock nuts.
13. → If installed, fit counterweight to non-driven side panel.
14. → If installed, fit the contactor control box to the non-driven side panel.
15. → When using electric trolleys, the tothing of the rollers on the powered side panel must be lubricated. → *Further information on page 82*
16. → Connect the control unit according to the wiring diagram.
17. → Track end limits must be fitted by the operator.
18. → Check the distance between the wheel flange of the rollers and the beam flange over the entire track.
→ Move the trolley through the whole track once, if necessary adjust the number of discs.

! NOTICE

The distance between the wheel flange of the rollers and the beam flange must be about 2 mm.

Checking movability

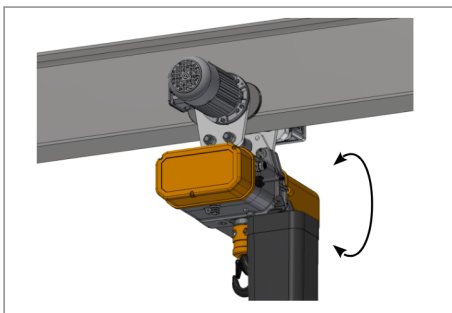

Fig. 47: Moveability

1. → Secure the electric chain hoist to the trolley with the original suspension bolts, washers and splints.
2. → Check the movability between the trolley and electric chain hoist.

! NOTICE

The movability between the trolley and the electric chain hoist must be possible in all directions shown.

i *The type of suspension lug of the electric chain hoist on the trolley depends on:*

- *Type of electric chain hoist*
- *The type of trolley*
- *The width of the beam flange*

Trolley with counterweight

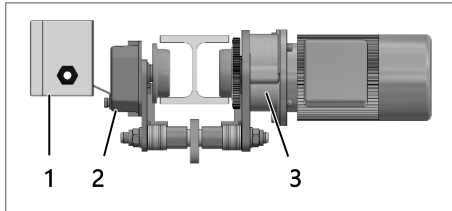

Fig. 48: Trolley counterweight

! NOTICE

When using an electric trolley, especially with two speeds on narrow beams, it may be necessary to use counterweights in order to prevent the trolley from tilting.

- 1 Contactor control (option)
- 2 Counterweight approx. 10 kg
- 3 Electric trolley



If necessary, the counterweight can be retrofitted on any trolley. It has no effect on the properties of the trolley.

Connecting the direct control

The electric trolley includes a cable and accessories for connecting to the electric chain hoist.

1. → Remove the brake cap of the electric chain hoist.
2. → Remove the trolley motor terminal box cap.
3. → Connect cables according to the wiring diagram.
4. → Fit the caps.

Connecting contactor control

The contactors for the travel drive motor are located in a separate housing.

1. → Secure the housing to the side panel of the trolley without the motor using hexagonal screws M8×10 DIN 933.
2. → Remove the brake cap of the electric chain hoist.
3. → Remove the cap of the trolley motor clamping box.
4. → Remove the cover of the contactor control box.
5. → Install the cable glands in the contactor control unit housing.
6. → Connect the two connecting cables according to the wiring diagram in the contactor control box and in the terminal compartments of the electric chain hoist and the travelling motor.
7. → Fit the caps.

Trolley limit stop

All electric trolleys can be fitted with a travel limit switch.

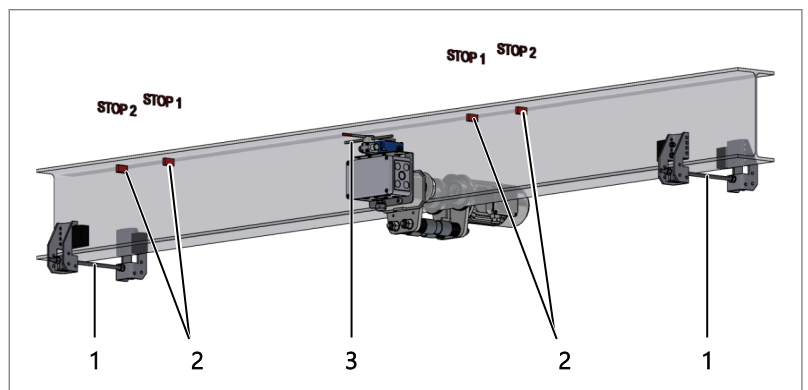

Fig. 49: Limit switch

- 1 End stop
- 2 Actuator
- 3 Travel limit switch

Gear ventilation

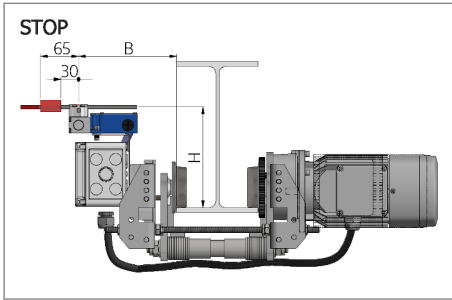

Fig. 50: Actuators

Tab. 18: Arrangement of actuators

WLL [kg]	H [mm]			W [mm]		
	N	S1	S2	N	S1	S2
500	170	170	150	190	155	100
1000	170	140	140	160	115	115
2000	170	140	140	160	115	115
3200	140	140	140	120	120	120
5000 / 6300	150	150	150	130	130	130

! NOTICE

The trolley limit stop actuators must be fitted by the operator at least 400 mm before the end stops.

4.7 Gear ventilation

Condition as supplied

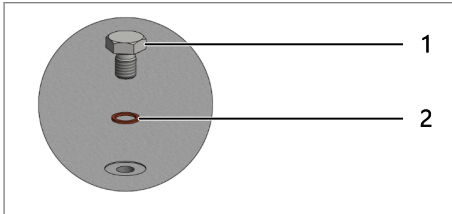

Fig. 51: Condition as supplied

- 1 Oil plug
- 2 Copper sealing ring

The oil plug for the electric chain hoists is provided with a copper sealing ring at the factory, which prevents gear oil from leaking during transport and assembly.

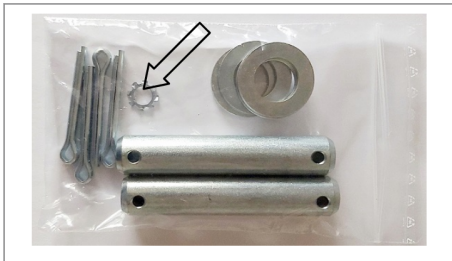

Fig. 52: Bolt set with serrated washer

When the electric chain hoist is delivered, the serrated washer is located together with the bolt set.

Gear ventilation by serrated washer

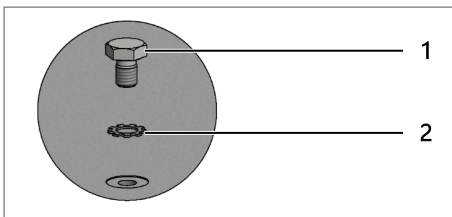

Fig. 53: Serrated washer gear ventilation

- 1 Oil plug
- 2 Serrated washer

After the electric chain hoist has been installed, the serrated washer must be fitted underneath the oil plug on the top of the housing. The oil plug must only be tightened by hand. The copper seal ring is removed.

The serrated washer is used for pressure compensation in the gear housing.

! NOTICE

For outdoor use and in very humid conditions, the use of the serrated washer is not recommended. The serrated washer must not be used for mobile applications or when the hoist is used as a climbing hoist. In this case, the copper sealing ring must be installed under the oil bolt.

4.8 Electrical connection

4.8.1 General information

DANGER

Live parts

There is danger to life and limb.

- Work on electrical equipment may only be carried out by qualified electricians.
- Before starting work, switch off the electrical power supply and secure it against unauthorised reactivation.

The electrical system must be installed in accordance with the applicable regulations.

After installation of the system, the tests in accordance with EN 60204-32 must be carried out. Details of the control can be seen in the wiring diagram. The electrical equipment of the electric chain hoist and the accessories correspond to the current version of EN 60204-32.

4.8.2 Fuse protection

The electrical connection data including fuse protection, cable lengths and cable cross section are described in chapter [Chapter 3.9 'Electrical data' on page 19](#).

4.8.3 Connecting

A main switch in accordance with EN 60204-32 must be provided to disconnect all poles from the mains power supply.

Installing the main switch is the responsibility of the operating company.

NOTICE







In order to ensure proper operation, the power supply must be connected to a clockwise rotating field and must be corrected if there is any deviation. If the connection was executed correctly, the electric chain hoist performs a lifting movement when the Lift button is pressed.

Before commissioning, check whether the mains voltage matches the voltage specification on the type plate.

Prior to the start of repair work, the system must be switched off and secured against unauthorised reactivation.

NOTICE

The terminals L1, L2, L3 and PE for the 3-phase mains connection are located under the cap.

1.  Remove the cap.
2.  Prepare a 3+PE cable for connection.
3.  Connect the power and control cable and the trolley in accordance with the wiring diagram.
4.  Fit the cap.
5.  Turn on the power.
6.  Press the Lift button.
 - ➔ If the load moves downwards, switch wires L1 and L2.

WARNING

Disconnect the system from power before doing this.

! NOTICE

1-phase mains connection

The wires L1, N and PE for the 1-phase mains connection are connected in the same way.

4.8.4 Pendant control

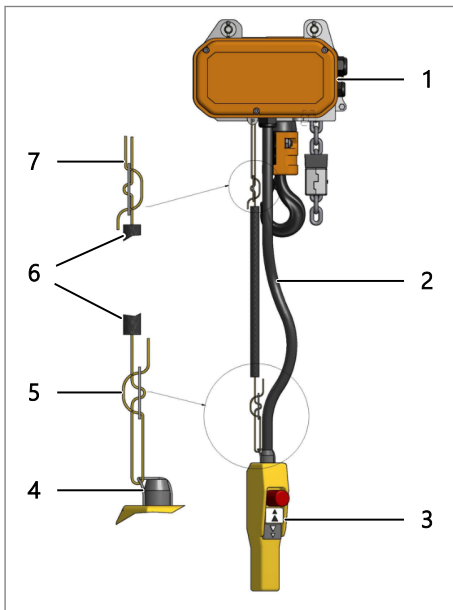

- 1 Electric chain hoist
- 2 Control cable
- 3 Pendant control
- 4 Pendant control bracket
- 5 Strain relief (lower node)
- 6 Protective cover
- 7 Strain relief (top node)

The length of the control line must be adapted to the local conditions.

The pendant control must be connected according to the wiring diagram.

The warning sign must be attached to the lower end of the control cable in a legible manner (cable ties).

! NOTICE

The strain relief (cord) of the pendant control must be secured in such a way that no pulling forces act on the control line.

Pulling on the pendant control is not permitted.

Fig. 54: Strain relief

4.8.5 Setting the gear limit switch

If the electric chain hoist is fitted with a gear limit switch, it must be set after the electric connection of the electric chain hoist. See the supplier documentation provided.



The emergency limit switches for lifting and lowering are not connected at the factory and cannot be evaluated in the electric chain hoist. They can be integrated into an external control unit by the customer.

5 Operation

5.1 Initial commissioning

5.1.1 Requirements for initial commissioning

In the Federal Republic of Germany, initial commissioning of the electric chain hoist must, for cranes, be carried out according to DGUV V52 by an expert or, for semi-powered lifting devices, according to DGUV V54 by a qualified person (≤ 1 t load capacity) or by an expert (> 1 t load capacity) (↔ Chapter 6.3.11.4 'Tests' on page 77).

The operator is responsible for arranging for the inspection before the initial commissioning.

The preparations for the initial commissioning are to be made by competent personnel.

The inspection must be carried out in accordance with DGUV G309-001 or the valid national standards and regulations.

! NOTICE

The use of the electric chain hoist without such inspection is not permitted.

5.1.2 Check before the initial commissioning

The assembly of the hoist was properly completed in accordance with the operating instructions.

The final assembly report is available and complies with the legal regulations or operating company requirements.

The end of assembly was noted in the test book.







! WARNING

Operational safety is not yet guaranteed during the initial commissioning of the hoist. There is a risk to life and limb if the hoist is put into operation without prior inspection.

! NOTICE

The check before the initial commissioning may only be carried out by a qualified person or expert. The maintenance engineers of the manufacturer can also be regarded as qualified specialists. However, the operator may also have appropriately trained specialists from their own company carry out the check before commissioning.

Before the initial commissioning, the following points must be observed:

1.  Wear protective equipment.
2.  Cordon off and secure the working and hazard area.
3.  Sufficient room for assembly is required.
4.  Check that the mains voltage and frequency match the specifications on the type plate.
5.  Check the proper installation and function of the safety equipment.
6.  Move the trolley by hand and check whether it can easily run on the whole track without obstacles and without endangering persons and objects.
7.  Check the end stops of the track.

5.1.3 Commissioning test**! WARNING**

The hoist may only be commissioned if it complies with the accident prevention regulations and national standards.

The commissioning test ensures that the load-bearing equipment and hoist can function reliably without restriction. The static and dynamic properties of the hoist must be observed.

The declaration of conformity of the hoist or crane must be available.

5.1.3.1 Scope of the test

- Identification of the crane, hoist including type plate, test book and documentation of the lifting gear and load hooks.
- Enter all actual values of the load hooks in the test book.
- Check the condition and load-bearing capacity of the support structure.
- Check the condition and load-bearing capacity of the hoist.
- Check the completeness and effectiveness of the safety equipment.

- Check the observance of safety distances and clearances.
- Check the EMERGENCY STOP device by pressing the EMERGENCY STOP button.









5.1.3.2 Test sequence

CAUTION

Test with extreme care.

Always keep the load near the ground.

Initiate the second working movement only when vibrations from the previous movement have ceased. Log deformations and vibrations.

1.  Check all functions without load.
2.  Check all safety equipment.
3.  Test with test load = 1.25x nominal load. This test is mainly used to check the support structure and brakes (static test).
4.  Test with test load = 1.1x nominal load (dynamic test).
 Check all the options for intended operation and all the functions with 1.1x nominal load. Carry out the dynamic test with overlapping of the possible working movements with maximum working speeds.
 - ➔ The load must be raised to 1.1 times the nominal load without changing the setting of the slip clutch.
5.  Check the behaviour of the hoist/crane in case of incorrect use.
6.  If installed, adjust the limit switch.
7.  Activate all safety devices.
8.  Record the completion of commissioning in the test book.
9.  Record the date for the first recurring inspection using a test badge and/or entry in the inspection book.
 - ➔ After successful completion of the commissioning test, the hoist or crane may be used as intended.

5.2 Operation

5.2.1 Qualification of operating personnel

- The operating personnel must be familiar with the electric chain hoist and its control system, know the structure and assembly processes before they are permitted to assemble or operate the electric chain hoist or the crane system.
- The operating personnel must have read and understood these operating instructions as well as the warning and safety instructions before assembly and commissioning.
- The operating personnel must comply with all national or state health and safety regulations during assembly and operation.
- The operating personnel must be familiar with the correct application of loads to the load hooks.
- The operating personnel must be trained in the detection of malfunction of the equipment requiring adjustment or repair. They must be instructed to immediately stop the operation in such cases and immediately inform their supervisor in order to initiate the troubleshooting.
- The operating personnel must have normal depth perception, angle/field of vision, reaction time, dexterity and coordination.

- The operating personnel must not be prone to convulsions, loss of control, physical discomfort or emotional instability which may result in an action by the operating personnel which may cause danger to the operating personnel or others.
- The operating personnel must not operate the electric chain hoist or crane system under the influence of alcohol, drugs or medication.

5.2.2 Safety instructions for operation



Country-specific rules

The country-specific operating regulations and occupational health and safety regulations must be observed during operation of the electric chain hoist or crane system.



CAUTION

Improper operation

Risk of injury and damage to property

- The electric chain hoist may only be operated by instructed persons.
- Operating personnel must be trained by the operator.
- Observe all safety and operating instructions.
- Safety devices must not be overridden or modified.



CAUTION

Falling parts / suspended loads

There is danger to life and limb.

- It is prohibited for persons to enter and stay in the hazard area.
- It is prohibited to lift loads over persons.



CAUTION

Risk of crushing

Risk of body parts being crushed or clothes and hair becoming caught.

- Do not touch the chain when it is moving.
- Do not reach into the chain inlets.
- When lifting, do not grip the load between the hook jaw and the load attachment device.
- No persons may be in the hazard area when the load is set down.



CAUTION

Risk of burns

Burns due to touching the heated motor housing.

- Do not touch the motor housing when it is hot.
- Allow the motor to cool before servicing and repair work.

5.2.3 Pendant control

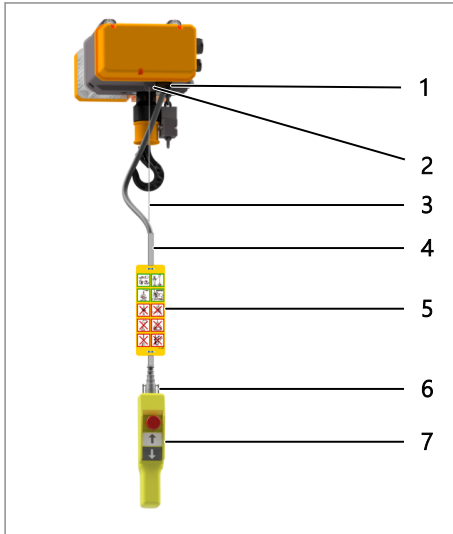

Fig. 55: Pendant control arrangement

- 1 Cable outlet on the housing
- 2 Strain relief attachment on the housing
- 3 Strain relief wire
- 4 Control cable
- 5 Warning sign
- 6 Wire bracket on pendant control
- 7 Pendant control with EMERGENCY STOP

! WARNING

Read and follow all warnings on the electric chain hoist.

! CAUTION

Pulling on the pendant control is not permitted.

! NOTICE

The slow speed may only be used for positioning, lifting or setting down the load or for starting and stopping the electric trolley. It is not permitted to travel long distances.

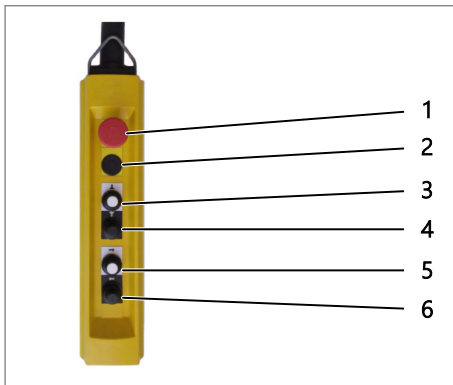

Fig. 56: Pendant control (example)

- 1 EMERGENCY STOP
- 2 Unassigned space
- 3 Lift
- 4 Lower
- 5 Travel right
- 6 Travel left



The space can be assigned by a selector switch (toggle switch).

Operating element	Type of operation	Function
Red mushroom button = EMERGENCY STOP	Press/hit the button	EMERGENCY STOP
	Turn the button to the right	Unlock
Direction buttons, one speed	Press button	Movement in the selected direction
Direction buttons, two speeds	Button pressed to 1st level	Movement in the selected direction at slow speed
	Button pressed to 2nd level	Movement in the selected direction at fast speed
Selector switch (option)	Toggle switch Position left – centre – right	According to selection option

EMERGENCY STOP

If the control unit is equipped with an EMERGENCY STOP option according to EN 60204-32, this red mushroom button is located on the pendant control.

! CAUTION

Pressing the EMERGENCY STOP button does not replace switching off the system by means of a main switch.

5.2.4 Radio remote control

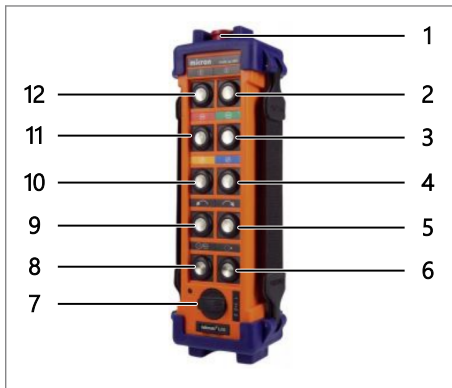

- 1 EMERGENCY STOP
- 2 Lower
- 3 Travel left
- 4 Travel back
- 5 Unassigned space
- 6 Unassigned space
- 7 Toggle switch
- 8 On/off switch
- 9 Unassigned space
- 10 Travel forward
- 11 Travel right
- 12 Lift

Fig. 57: Radio remote control (example)



The original operating instructions of the manufacturer of the radio remote control are supplied.

5.2.5 Attaching the load

The following points must be observed when attaching the load to the hoist:

- Always position the hoist vertically above the load.
- The load may only be attached using the load hook.
- The load must always be in the hook jaw base. The load must not be attached to the tip of the load hook. This also applies to the suspension hook.
- If necessary, lashing must be used to properly attach the load.
- The load must be properly attached.
- The hook lock nut must be closed.
- Before lifting the load, check that the lifting gear is not twisted.
- Before the lifting operation begins, the lifting gear must be taut.
- Lifting of the load with loose lifting gear and full lifting speed is not permitted.
- Avoid swinging the load or the load hook.

! NOTICE

Do not guide load chains over edges.

Looping of loads with the lifting gear is prohibited.

! NOTICE

The operating personnel or a second person must always be in visual contact with the load during lifting process and movement of the load.

! NOTICE

The load must be able to move freely. There must be no obstacles in the working area.

⚠ CAUTION

Never use the load chain as a sling chain.

Only use approved and certified slings or lashing to secure the load.

5.3 Operation

5.3.1 Proper operation

The hoist is intended for lifting and lowering loads. In the case of hoists with a trolley, the intended operation comprises lifting, lowering and horizontal movement of the raised loads.

CAUTION

Incorrect operation can lead to serious personal injury and/or damage to property.

Transport of persons, towing and pulling of loads, diagonal pulling and lifting of fixed loads are not part of the intended operation and are therefore prohibited.

Note the prohibitions for use!

All manners of operation which deviate from the intended operation can lead to danger of injury, serious personal injury and/or damage to property. The hoist may only be operated by trained and authorised personnel. The operator must arrange for the instruction and training of the operating personnel.

All accident and safety regulations as well as national regulations for the use of hoists must be observed and adhered to.

5.3.2 Residual risks

Risk of crushing

- Due to the way in which they are constructed, there is the risk of body parts being crushed or clothing and hair getting caught by the lifting gear or the load hook when using hoists.

CAUTION

Do not touch the chain when it is moving.

Do not reach into the chain inlet.

Do not touch the area between the hook jaw base and load attachment device; wear protective gloves.

In the case of low crane runways, do not touch or lean on the track surface.

Risk of burning

- In the case of intensive operation, parts of the hoist housing or motor can reach high temperatures.

CAUTION

There is a risk of burning during operation of the hoist.

Do not touch the hoist during operation.

Suspended load / falling parts

- During the operation of the lifting device, suspended loads or parts thereof may fall down.

CAUTION

It is prohibited for persons to stand under suspended loads.

It is prohibited to lift and move loads over persons.

The hazard areas of the hoist must be marked.

The personnel must be instructed accordingly and must wear protective equipment.

5.3.3 Working with the hoist

5.3.3.1 Start of work

CAUTION

The operating personnel must check the correct and operationally safe condition of the hoist before starting work.

In the event of safety-related defects or damage to the hoist, including the associated components, the hoist must be stopped immediately.

Pre-work checks (daily check)

- Damage to load-bearing parts such as chain, hooks, suspension, support structure, etc.
- Twisted mounted load chain or swivelled hook block
- Check load chain for sufficient lubrication
- Damage to electrical equipment, wiring and insulation
- Failure or delayed operation of brakes, limit switches and safety devices
- Absence of housing parts, covers or rubber buffers

NOTICE

Wear protective equipment when working with hoists.

Always check that there are no persons in the hazard area of the hoist before switching it on.

Brake function test

- Lift without load and stop the hoist.
- Lower without load and stop the hoist. Both movements must come to a standstill without problems.
- Position the hoist vertically above the load.
- Attach the load.
- Lift with load and bring the hoist to a standstill after a short lifting distance. It must be possible to stop the lifting movement without difficulty. The load must not slip.
- Lower with load and bring the hoist to a standstill after a short distance. It must be possible to stop the lowering movement without difficulty. The braking distance should be about two chain links. For hoists with lifting speeds of > 8 m/min, the braking distance may not exceed 1/60 of the lifting speed (in mm).

CAUTION

The operating personnel must check the operability of the brake before starting work.

Functional inspection of limit switches (if installed)

- Visual inspection, checking for mechanical damage, ease of movement, corrosion
- Function check of the lift limit switch: Execute a movement in the Lift direction and trigger the limit switch for lifting. The movement must be stopped.
- Function check of the lower limit switch: Execute a movement in the Lower direction and trigger the limit switch for lowering. The movement must be stopped.

Further checks

- For hoists with a trolley, the whole track surface must be checked for obstacles.
- The presence of the track end limits must be verified.

- The presence of buffers on the track end limits shall be checked.
- The labelling and accessibility of the crane main switch must be checked.

5.3.3.2 Operating information

CAUTION

The operating personnel must immediately stop their work with the hoist if they notice persons in the hazard area of the hoist. They may not continue the work until the persons have left the hazard area.

Any person who identifies hazards to other persons or safety-related damage or defects on the hoist must immediately switch off the hoist.

If the hoist has been switched off due to a safety deficiency, it must be secured against unauthorised reactivation. A qualified person must verify whether the cause of the hazard has been removed and whether it is possible to resume operation without hazard.

CAUTION

By pressing the red EMERGENCY STOP button, all movements can be stopped in an emergency.

This does not de-energise the hoist!

To unlock the EMERGENCY STOP button, turn it clockwise.

General notes

- Observe the prohibitions for use and instructions for use in these operating instructions.
- Deliberately triggering the safety device (slip clutch) during normal operation is prohibited.
- The safety devices of the hoist and the associated components must not be overridden.
- Attached loads must not be left unattended.

Instructions for attaching the load

- Always position the load vertically under the hoist.
- Always hook the load in the base of the hook.
- The hook tip must not be loaded.
- The hook lock nut must be closed.
- Removing the hook lock nut / safety catch or working with an open hook lock nut / safety catch is prohibited.
- The load chain must not be guided over edges or used as a carrying sling.

Instructions for lifting and lowering the load

- Before you work with the hoist, you should be in a position where you can view the entire workspace. If this is not possible, a second person who can see the working area must be brought in.
- The lifting process is started by pressing the corresponding buttons on the pendant control.
- Lifting the load off the ground must be done at the lowest possible lifting speed.
- The load chain must not be slack before lifting the load off the ground. It must first be tensioned at the lowest possible lifting speed.
- The low speed may only be used for short lifting distances.
- Jog mode is prohibited.
- Observe the permitted duty cycle of the hoist.

Instructions regarding horizontal movement of the load

- The load is moved horizontally by actuating the pendant control when using an electric trolley.
- In the case of manual trolleys, the load may only be moved by pushing the hoist or the attached load.
- The load must be guided and must not be thrown.
- Pulling on the pendant control is prohibited!

5.3.3.3 Decommissioning

Decommissioning due to errors

The hoist must be switched off immediately:

- in the event of damage or failure of the operating elements, such as pendant control or radio remote control
- in the event of damage to electrical equipment, wiring and insulation
- in the event of failure of the brakes and safety devices

Decommissioning due to end of work

When leaving the workstation or at the end of the work, the operating personnel must take the following safety measures:

- The hoist must be parked without load.
- The operating personnel must position the hoist outside the traffic area in the parking position.
- The EMERGENCY STOP button must be pressed (if present).
- The hoist must be turned off at the main switch or circuit breaker.

Decommissioning due to maintenance work

Maintenance work may only be carried out by qualified persons.

- Prior to maintenance work, the main switch or the circuit breaker of the hoist must be switched off and secured against unauthorised or accidental reactivation.
- Maintenance work may only be carried out on the hoist in an unloaded state.
- Movable parts must be secured against falling or removed from the hoist.
- When servicing hoists, observe the applicable regulations of the DGUV, the official regulations and the instructions for their proper use.
- Only specialists may perform maintenance work on the electrical equipment. Standards EN 60204-1 and EN 60204-32 must be complied with.

5.4 Duty cycle

5.4.1 Duty cycle of the electric chain hoist

Duty cycles according to FEM 9.683

CAUTION

The permissible switching cycle number and the duty cycle according to FEM 9.683 must not be exceeded. The permitted duty cycle is shown in the type plate of the electric chain hoist.

Driving mechanism group		Short-term operation		Intermittent operation	
FEM 9.511	ISO 4301	Activation time t_B		Duty cycle	Pause t_P
		Low-pole	High-pole		
		[min]	[min]	[%]	[min]
1 Bm	M 3	15	2.5	25	3x t_B
1 Am	M 4	15	3.0	30	2,5x t_B

Duty cycle > Duty cycle of the electric chain hoist

Driving mechanism group		Short-term operation		Intermittent operation	
FEM 9.511	ISO 4301	Activation time t_B		Duty cycle	Pause t_P
		Low-pole	High-pole		
		[min]	[min]	[%]	[min]
2 m	M 5	30	3.5	40	1,5x t_B
3 m	M 6	30	4	50	1x t_B
3 m	M 6	60	5	60	0,66x t_B
4 m	M 7	60	5	60	0,66x t_B

! NOTICE

Creep hoist is only to be used for the slow, delicate setting down and lifting of the load. It is not suitable for reaching greater heights.



A temperature monitor can be installed to protect the motor against overheating.

Attention: Contactor control required

$$ED (\%) = \frac{\sum t_B \times 100 \%}{\sum t_B + \sum t_P}$$

The duty cycle ED (%) of the electric chain hoist is the ratio between the operating times and the operating times + downtimes.

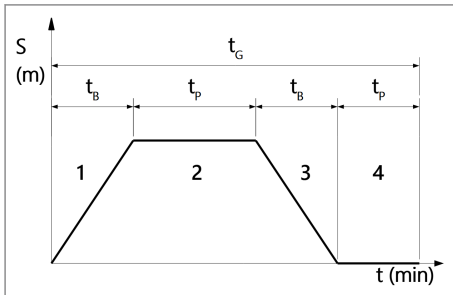

- 1 Lift
- 2 Pause/travel
- 3 Lower
- 4 Pause/unload
- t_G Total lifting cycle
- t_B Operating time
- t_P Downtime

The operating time depends on the lifting height, the lifting speed of the electric chain hoist and the number of lifting movements for a specific transport process (unloading of lorries, loading of machinery).

Fig. 58: Duty cycle



The duty cycle of the electric chain hoist is limited by the permitted heating of the lift motor.

The operating times t_B of the electric chain hoists are higher than required by FEM 9.683.

5.4.1.1 Short-term operation according to FEM 9.683

In this operating mode, a lift motor cooled to the temperature of the coolant can be operated for a certain amount of time with a load corresponding to the respective driving mechanism group. After the maximum permissible operating time has been reached, breaks must be taken and the electric chain hoist must be operated in intermittent mode.



CAUTION

This operating mode is not permitted for the slow speed of the lift motor of the electric chain hoist.

5.4.1.2 Intermittent operation according to FEM 9.683

Depending on the duty cycle, certain pause times must be observed until the electric chain hoist can be operated further.

5.4.1.3 Calculation of operating and pause times

Example

A hoist should lift a 1000 kg load 6 m high. The lifting speed should be 6 m/min.

Tab. 19: Performance data

Load capacity	1000 kg
Lift speed	6 m/min
Driving mechanism group	2m/M5 (manufacturer's specification)

At the start of operation, the hoist has a temperature of 20 °C.

Calculating the operating time for a lifting cycle:

Operating time = [6 m (lifting) + 6 m (lowering)] / 6 m/min

Operating time = 2 min per lifting cycle

In short-term operation the hoist can work for approx. 30 min without interruption according to FEM 9.683 in driving mechanism group 2m/M5. This corresponds to 15 lifting cycles and 15000 kg of transport goods.

After reaching 30 minutes of operation, the hoist can be operated further in intermittent operation.

The duty cycle for the driving mechanism group 2m/M5 according to FEM 9.683 is 40%. This means that a pause of 1.5 times the operating time must be taken after each operating time.

This pause is usually required for the attachment and removal of the load.

5.4.2 Trolley duty cycle



For hoists with an electric trolley, the operator must observe the permitted duty cycle of the electric trolley.

This applies in particular to very long distances.

CAUTION

The permitted operating time and the duty cycle must not be exceeded (see FEM 9.683). The permitted duty cycle is shown in the following table.

Number of travel speeds	Short-term operation t_B [min]	Intermittent operation	
		Duty cycle [%]	Pause t_P [min]
1	30	40	30
2	30	40/20	30

CAUTION

The indicated permissible operating time refers only to the rapid travelling speed of the electric trolley.

5.5 Tests

5.5.1 Type test

The electric chain hoists including the associated trolley are type-tested.

The dynamic and static tests of the hoist according to the EC Machinery Directive were carried out by the manufacturer. The factory test is certified with the test book.

Tests > Assignment to the relevant accident prevention regulations

5.5.2 Guidelines and standards

! NOTICE

The test regulations apply to Germany. In other countries, the applicable national or federal accident prevention regulations must be observed.

Work on the electric chain hoist may only be carried out by trained persons (qualified persons/experts) after the power supply has been switched off and the work area has been secured.

The electric chain hoists can be used according to the following regulations:

- DGUV V54 – Winches, lifting and pulling equipment
or
- DGUV V52 – Cranes

The testing of the hoist before initial commissioning, after substantial changes and the repeated tests are to be organised by the **operator**.

In principle, the Section 4.1.3 of Annex I of the EC Machinery Directive “Suitability for purpose” applies.

! NOTICE



In the case of severe operating conditions, e.g. frequent operation with full load, dusty or aggressive environment, high switching frequency, long duty cycles, the test intervals must be shortened.

i *The remaining useful life in accordance with FEM 9.755 must be determined upon each recurring inspection and recorded.*

5.5.3 Assignment to the relevant accident prevention regulations

The assignment of an electric chain hoist to the corresponding regulation depends on the installation situation and on the number of movement directions.

The hoist must be assigned to a category for testing before initial commissioning and after significant changes:

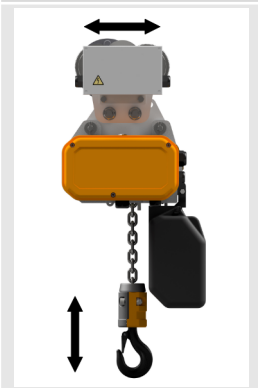
Stationary suspension	Suspension with manual trolley	Suspension with electric trolley
		
DGUV V54	DGUV V52	DGUV V52

i *The operator is responsible for carrying out the risk assessment for assigning the electric chain hoist to the corresponding regulation.*

5.5.4 Testing when used in accordance with DGUV V54, Section 23

According to DGUV V54, Section 23, power-driven hoists must be tested as follows:

Test	Inspector
Pre-commissioning test	Person qualified to perform the test
Checking for significant changes before recommissioning	Person qualified to perform the test
Recurring inspections (at least once a year)	Person qualified to perform the test

5.5.5 Testing when used in accordance with DGUV V52, Section 25 and 26

According to DGUV V52, Section 25 and 26, cranes must be tested as follows:

Test	Inspector
Pre-commissioning test	Expert
Checking for significant changes before recommissioning	Expert
Recurring inspections (at least once a year)	Person qualified to perform the test

For the electric chain hoist version with manual trolley suspension **and** a load-bearing capacity of ≤ 1000 kg (semi-powered cranes), the following applies by way of derogation:

Test	Inspector
Pre-commissioning test	Person qualified to perform the test
Checking for significant changes before recommissioning	Person qualified to perform the test
Recurring inspections (at least once a year)	Person qualified to perform the test

6 Maintenance

6.1 Replacement parts

Use only original fastening parts, replacement parts, wear parts and accessories from the manufacturer. Only these parts are covered by the warranty.

! NOTICE

The use of parts that are not approved by the manufacturer can lead to unforeseen hazards, damage, malfunctions or the total failure of the electric chain hoist.

The manufacturer does not assume any liability for damages caused by the use of non-original parts and accessories.

The replacement parts lists are available on the manufacturer's website.



If a required part cannot be identified, contact the manufacturer or its authorised partners. For this, have the serial number of the electric chain hoist ready.

6.2 Maintenance intervals – Table

i *The electric chain hoist is dimensioned according to FEM 9.511. The remaining service life according to FEM 9.755 must be determined and documented annually.*

If the calculation of the remaining service life is complete, a general overhaul of the electric chain hoist must be carried out when the theoretical end of the service life is reached. If there is no evidence of the use of the electric chain hoist, a general overhaul must be carried out after 10 years at the latest in accordance with FEM 9.755.

! NOTICE

The time intervals are reference values.

In the case of harsh operating conditions, the time intervals must be shortened by the operator. These include, for example, multi-shift operation, constant operation with nominal load, dust, high stress due to aggressive environment, extreme temperatures and environmental influences.

Interval	Maintenance work
Daily	Visual check <ul style="list-style-type: none"> ■ Overall condition ■ Load chain ■ Fastening elements ■ Pendant control, control cable and strain relief, power cable ■ Hook lock nut ■ Rubber buffer Functional inspection <ul style="list-style-type: none"> ■ Lifting/lowering ■ Travel (all directions of movement) ■ All limit switches ■ EMERGENCY STOP ■ Brake
3 months	Wear test <ul style="list-style-type: none"> ■ Load chain Visual check <ul style="list-style-type: none"> ■ Chain box and chain box fastener ■ Proximity buffer Maintenance <ul style="list-style-type: none"> ■ Lubricate load chain
Annually	Visual check <ul style="list-style-type: none"> ■ Screw connections ■ Downholder and chain guide ■ Load hooks and suspension hooks for cracking and rust ■ Trolley and rollers ■ Housing suspension points ■ Chain box fastening points ■ Pendant control, control cable and strain relief, power cable ■ Presence and readability of operating instructions ■ Completeness and readability of all warnings

Interval	Maintenance work
Annually	<p>Functional inspection</p> <ul style="list-style-type: none"> ■ Lifting/lowering ■ Travel (all directions of movement) ■ All limit switches ■ EMERGENCY STOP ■ Slip clutch ■ Brake test with full load ■ Motor fan wheel <p>Wear test</p> <ul style="list-style-type: none"> ■ Chain sprocket If there wear has reached a depth of approx. 1 mm on the running surface, replace ■ Load hook Check the spacing or the hook jaw width and height of the hook in the base of the hook ⇒ Compare with the dimensions in the test book Check the hook lock nut ■ Suspension hook Check the spacing or the hook jaw width and height of the hook in the base of the hook ⇒ Compare with the dimensions in the test book Check the hook lock nut ■ Chain suspension Visual inspection Check the chain and clamp diameters If the chain suspension is at $d_m \leq 0.9 d$, replace \leq <p>Maintenance</p> <ul style="list-style-type: none"> ■ Grease hook tackle, hook block, suspension hook ■ Clutch Check the trigger limit Adjust the clutch

6.3 Maintenance work

All maintenance work may only be carried out by competent persons. Defects must be communicated to the operator immediately in writing. The operator shall arrange for the correction of these deficiencies.

DANGER

Electric shock

There is danger to life and limb.

- Maintenance work may only be carried out on the electric chain hoist when it is in an unloaded and voltage-free state.
- Switch OFF the main switch and secure it against unauthorised reactivation.

NOTICE

Pressing the EMERGENCY STOP button does not replace switching off the system at the main switch.

Maintenance work > Load and suspension hooks

6.3.1 Housing

Visual inspection

The housing must not have any visible damage:

- Check the suspension point of the housing for cracks, especially when using screw connections for suspending the electric chain hoist.
- The bores of the suspension points must not be worn.
- Cable glands must be firmly seated on the housing and must not be damaged.

6.3.2 trolley

Visual inspection

The trolley must not have any visible damage:

- The side panels of the trolley must not be bent or damaged.
- The motor and in particular the fan cap must not be damaged.
- The suspension eye bores must not be worn.
- Cable glands must be firmly seated on the housing and must not be damaged.

6.3.3 Load and suspension hooks

Wear test on the hooks

Load and suspension hooks are lifting gear subject to inspection. The national and regional rules for load and suspension hooks in hoist operation must be complied with. Load and suspension hooks of hoists must be monitored on an ongoing basis.

CAUTION

The load and suspension hooks must be checked before commissioning and annually under normal operating conditions, and at shorter intervals under harsh operating conditions.

The actual values of the jaw opening width and the hook jaw base must be entered in the test book by the operator during initial commissioning.

The load and suspension hooks must be replaced in the following cases:

- Expansion greater than 10 %
- Reduction in hook jaw base height by more than 5%
- Sharp indentations and cracks in the hook jaw base



CAUTION

Safety hook

Safety hooks are to be subjected to a crack test every 2 years.

- Load with 1.5x WLL
- Then perform a visual inspection, magnetic crack test and dye-penetrant technique.

Procedure for wear test

1.  Visual inspection of the hook for wear, cracking, deformation and other damage. Visual inspection to ensure that the hook lock is free from deformation and closing securely.
 Visual inspection of the spring trigger and hook guard, if fitted.
 - In the event of visible damage, replace the hook immediately.
2.  Check the function of the thrust bearing; clean and lubricate it if necessary. The hook must rotate easily.

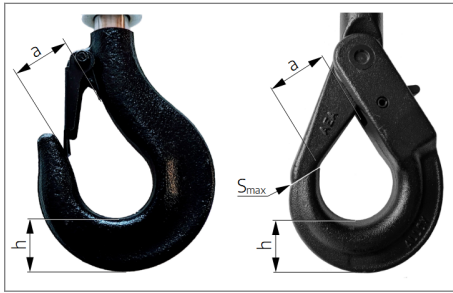

Fig. 59: Measuring hook wear

- Measure dimension a (hook throat opening, from the centre of the hook throats) and dimension h. Compare to the actual registered value from the hook certificate in the inspection book.

Safety hook:
the permissible opening at the hook tip must not exceed $2x S_{max}$.

➔ When a wear limit is reached, you must replace the hook.



When replacing a hook, enter all the actual values in the inspection book.

6.3.4 Load chain

6.3.4.1 Load chain wear test

Hoist chains are considered lifting gear that is subject to inspection. The national and regional rules for round steel chains in hoist operation must be complied with. Load chains of hoists must be monitored on an ongoing basis.

CAUTION

The load chain must be checked before commissioning and under normal operating conditions after approx. 200 hours of operation or 10,000 load cycles, in case of harsh operating conditions at shorter intervals.

The load chain must be replaced in the following cases:

- Reduction of the nominal thickness at contact points by 10 %
- Elongation of one chain link by 5 %
- Elongation of the chain per 11 chain links by 2%
- Chain links are stiffened

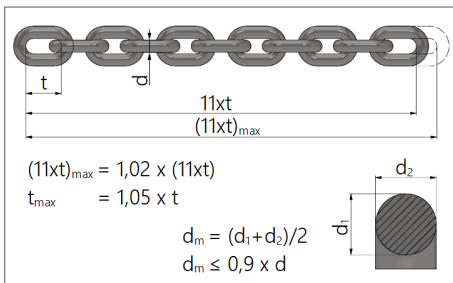

Fig. 60: Chain dimensions

- d Nominal diameter of the chain link (not measured at the weld)
- d₁ First measurement diameter of chain link
- d₂ Second measurement diameter of the chain link
- d_m Mean diameter of the chain link
- t Chain link pitch
- t_{max} Wear limit of the pitch of a chain link
- 11xt Pitch of 11 chain links
- (11xt)_{max} Wear limit of the pitch of 11 chain links

Tab. 20: Chain dimensions

dxt	d	0.9xd	t	t _{max}	11xt	(11xt) _{max}
[mm]	[mm]	[mm]	[mm]	[mm]	[mm]	[mm]
5x15	5	4.5	15	15.8	165	168.3
5.2x15	5.2	4.7	15	15.8	165	168.3
7x22	7	6.3	22	23.1	242	246.8
7.2x21	7.2	6.5	21	22.1	231	235.6
9x27	9	8.1	27	28.4	297	302.9
11.3x31	11.3	10.2	31	32.6	341	347.8

Procedure for wear test



- Visual inspection over the whole length of the load chain for wear, cracking, deformation and other damage.

NOTICE

In particular, check the contact points of the chain links and the chain in the region of the upper and lower hook positions.

➔ In case of visible damage, replace the chain immediately.

- Measure thickness d₁ and d₂ at the contact point of the chain links.

3.  Calculate the mean diameter $d_m = (d_1 + d_2)/2$.
 - ➔ If $d_m \leq 0.9 \times d$, the chain must be replaced.
4.  Measure the pitch of a chain link.
 - ➔ If the wear limit t_{max} is exceeded, the chain must be replaced.
5.  Measure the pitch of 11 chain links.
 - ➔ If the wear limit $(11xt)_{max}$ is exceeded, the chain must be replaced.



Using a limit gauge

The chain should be discarded when the limit gauge can no longer be inserted into the chain.

6.3.4.2 Chain end fastener

Chain end fastener wear test

Chain end fasteners are safety-relevant components and must be monitored continuously.

WARNING

Risk of falling load

Only the original chain clamp of the manufacturer may be used.

The chain end fastener must be replaced in the following cases:



- Reduction of the nominal thickness of the chain clamps/bolts and chain links at contact points by 10%
- Elongation of one chain link by 5%

Procedure for wear test

1.  Visual inspection of the chain end fastener for wear, cracking, deformation and other damage.

NOTICE

Check all contact points of the chain clamps/bolts and chain links as well as the chain pockets in the housing.

- ➔ In case of visible damage, replace the chain end fastener immediately.
2.  Measure the thickness d_1 and d_2 of the chain clamps/bolts and the chain link at worn points.
 3.  Calculate the mean diameter $d_m = (d_1 + d_2)/2$.
 - ➔ If $d_m < 0,9 \times d$, the chain end fastener must be replaced.
 4.  Measure the pitch of a chain link.
 - ➔ If the wear limit t_{max} is exceeded, the chain must be replaced.



Replacing the chain end fastener

- Change chain clamps/bolts.
- Replace the chain link by shortening or replacing the load chain.

6.3.4.3 Replacing the load chain

Version 1/1

NOTICE

When replacing the load chain, the chain guide and the downholder must also be replaced.

Requirements for assembly:

- Have the new load chain, chain guide and downholders from the manufacturer ready at hand.
- Prepare the assembly chain and connecting link.



Assembly chain

The assembly chain can be made from a piece of an old load chain of the same chain size.

Tab. 21: Assembly chains

Chain size	Chain links
[mm x mm]	Minimum number
5x15; 5.2x15	23
7x22; 7.2x21; 9x27; 11.3x31	19

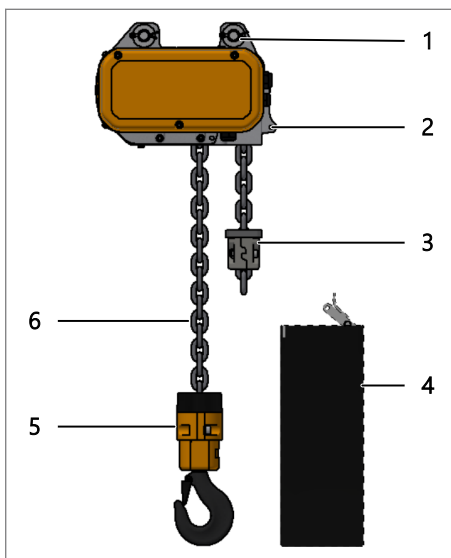

Fig. 61: Removing the chain box

1. Suspension bolt
 2. Chain box screw
 3. Lift limiter with rubber buffer
 4. Chain box
 5. Hook tackle with rubber buffer
 6. Worn load chain
1. ➤ Press the Lower button and move the hook tackle until just before the lowest position.
 2. ➤ Remove the chain box.
 3. ➤ Remove the lift limiter including the rubber buffer.
 4. ➤ Press the Lift button and move the hook tackle up to approx. 0.2 m below the housing of the electric chain hoist. Allow the worn chain to run into a suitable container.
 5. ➤ Remove the hook tackle including the rubber buffer.
 6. ➤ Push the Lift button and let the worn load chain run completely out of the electric chain hoist and into the container.
 7. ➤ Remove the electric chain hoist from the suspension and place overhead on a fixed work surface.
 8. ➤ Remove the chain guide.
 9. ➤ Slide the downholder out of the housing.
 10. ➤ Slide the new downholder into the housing.
 11. ➤ Manually place the assembly chain on the pinion shaft and allow it to run in gently with motor power.

! NOTICE

Insert assembly chain, starting with the flat chain link.

⚠ WARNING

Risk of crushing

Risk of fingers being crushed

- Do not reach into the housing.
- Wear protective gloves.

12. ➤ Push the ends of the assembly chain through the new chain guide and mount the new chain guide.
13. ➤ Suspend the electric chain hoist again with original connectors.

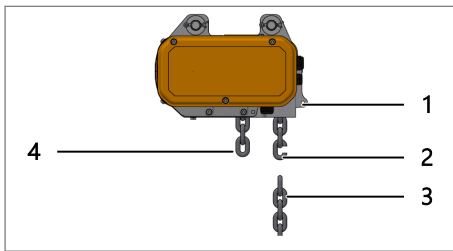

Fig. 62: Connecting the load chain

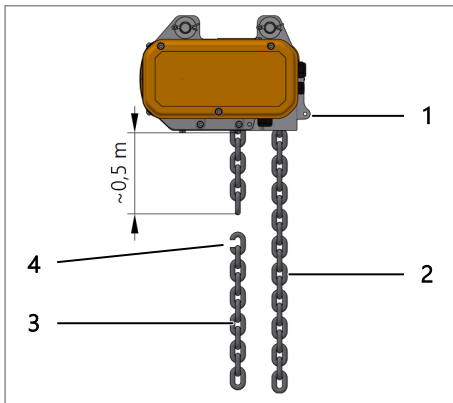

Fig. 63: Removing the assembly chain

- 1 Chain box side
- 2 Connecting link
- 3 Load chain
- 4 Assembly chain

14. ➤ Connect the connecting link to the chain end on the chain box side.

! NOTICE

The opening of the connecting link should be facing outwards.

15. ➤ Connect the new load chain with the connecting link.

16. ➤ Press the Lower button.

Allow the new load chain to be guided into the housing until approx. 0.5 m of the load chain remains on the load side.

- 1 Chain box side
- 2 Load chain
- 3 Assembly chain
- 4 Connecting link

17. ➤ Remove the assembly chain and connecting link.

18. ➤ Mount the hook tackle including rubber buffer and spring trigger (option).

19. ➤ Press the Lower button and move the hook tackle until just before the lowest position.

20. ➤ Fit the lift limiter including rubber buffer at the chain end to the chain box side.

! NOTICE

Load chain running out from the chain box

- Standard: fit the lift limiter to the third link before the chain end.
- Special version: The chain end of the load chain is attached to the electric chain hoist. The lift limiter must be mounted in such a way that the lift limiter lies on the floor of the chain box.

21. ➤ Insert the lift limiter into the chain box.

22. ➤ Attach the chain box.

23. ➤ Press the Lift button and allow the chain to go into the chain box.



At the same time, lubricate the entire length of the chain well.

Version 2/1

! WARNING

Risk of falling load

Only the original chain clamp of the manufacturer may be used.

! NOTICE

When replacing the load chain, the chain guide and the downholder must always be replaced as well.

Requirements for assembly:

- Have the new load chain, chain guide and downholders from the manufacturer ready at hand.
- Prepare the assembly chain, connecting link and pulling device (cable ties).



Assembly chain

The assembly chain can be made from a piece of an old load chain of the same chain size.

Tab. 22: Assembly chains

Chain size	Chain links
[mm x mm]	Minimum number
5x15; 5.2x15	23
7x22; 7.2x21; 9x27; 11.3x31	19

1. → Press the Lower button and move the hook block until just before the lowest position.
2. → Remove the chain box.
3. → Remove the lift limiter including the rubber buffer.
4. → Press the Lift button and move the hook block up to approx. 0.2 m below the housing of the electric chain hoist. Allow the worn chain to run into a suitable container.
5. → Release the chain guide and slide it downwards.

- 1 Chain box side
- 2 Chain guide
- 3 Worn load chain
- 4 Container
- 5 Hook block
- 6 Securing element (screwdriver)
- 7 Holder for chain clamp

6. → Pull back the chain clamp until the chain link is released.

! NOTICE

Risk of falling hook block

Insert the securing element (screwdriver) into the chain link above the hook block on the chain end fastener side. This prevents the chain from escaping from the hook block.

7. → Secure the chain guide to the housing again.
8. → Hold the hook block including the rubber buffer and remove the securing element. Remove the chain from the hook block including the rubber buffer.
9. → Push the Lift button and let the worn load chain run completely out of the electric chain hoist and into the container.
10. → Remove the electric chain hoist from the suspension and place overhead on a fixed work surface.
11. → Remove the chain guide.
12. → Slide the downholder out of the housing.
13. → Slide the new downholder into the housing.

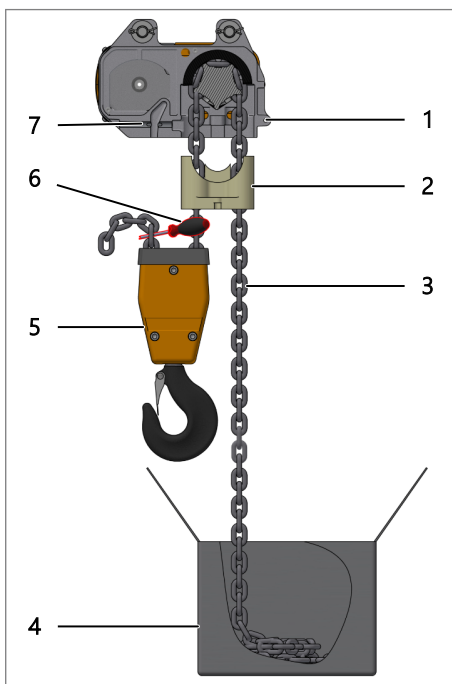

Fig. 64: Setting down the worn load chain

14. ➤ Manually place the assembly chain on the pinion shaft and allow it to run in gently with motor power.

! NOTICE

Insert assembly chain, starting with the flat chain link.

! WARNING

Risk of crushing

Risk of fingers being crushed

- Do not reach into the housing.
- Wear protective gloves.

15. ➤ Push the ends of the assembly chain through the new chain guide and mount the new chain guide.

16. ➤ Suspend the electric chain hoist again with original connectors.

- 1 Chain box side
- 2 Connecting link
- 3 Load chain
- 4 Assembly chain

17. ➤ Connect the connecting link to the chain end on the chain box side.

! NOTICE

The opening of the connecting link should be facing outwards.

18. ➤ Connect the new load chain with the connecting link.

19. ➤ Press the Lower button.
Allow the new load chain to be guided into the housing until approx. 0.5 m of the load chain remains on the load side.

- 1 Chain box side
- 2 Load chain
- 3 Assembly chain
- 4 Connecting link

20. ➤ Remove the assembly chain and connecting link.

21. ➤ Pull the assembly chain through the hook block with the pulling device (cable ties).

! NOTICE

Insert assembly chain, starting with the flat chain link.

- 1 Connecting link
- 2 Assembly chain
- 3 Securing element (screwdriver)
- 4 Hook block

22. ➤ Insert the securing element into the assembly chain on one side of the hook block.

23. ➤ Hook the connecting link into the other side and hook it to the load chain.

24. ➤ Manually pull the assembly chain and connecting link through the hook block.

25. ➤ Insert the securing element into the load chain above the hook block.

➔ Test: The chain must not be twisted between the chain guide and the hook block.

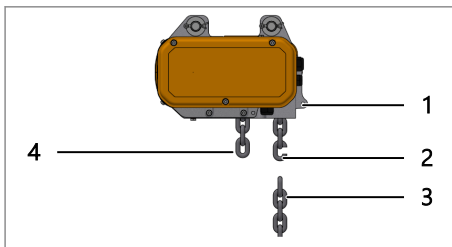

Fig. 65: Connecting the load chain

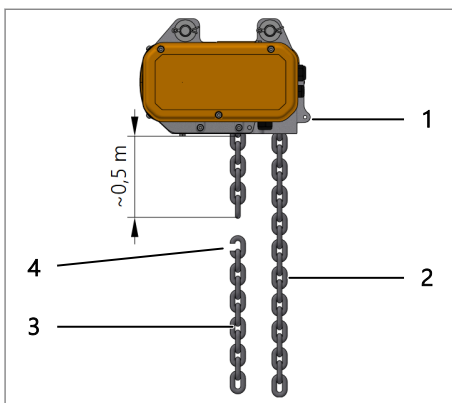

Fig. 66: Removing the assembly chain

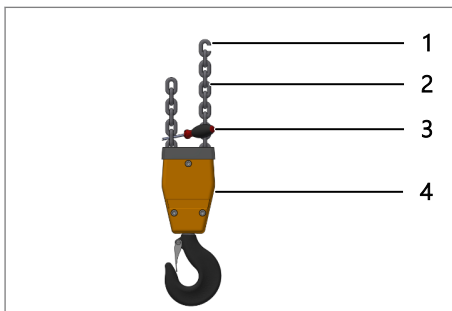

Fig. 67: Securing the assembly chain

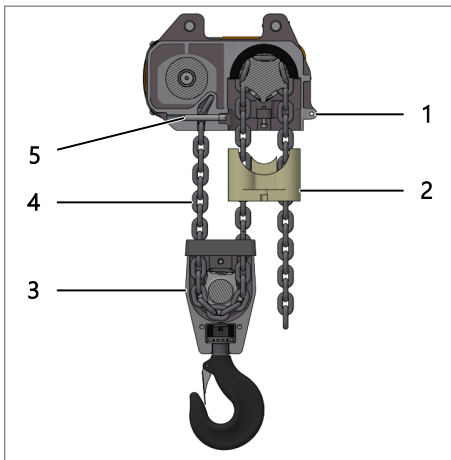

Fig. 68: Attaching the chain end

26. ➤ Remove the assembly chain and connecting link.

27. ➤ Release the chain guide.

- 1 Chain box side
- 2 Chain guide
- 3 Hook block
- 4 Load chain
- 5 Chain clamp

28. ➤ Insert the chain into the housing through the cross-shaped opening until the first chain link protrudes inside the housing.

29. ➤ Hold the chain in this position with one hand and push the chain clamp back in with the other hand.

➔ Check for tight fit by pulling on the chain sharply.

⚠ CAUTION

Risk of falling load

- The chain must not be twisted between the chain guide and the hook block.

If assembly without a twisted chain is not possible, shorten the chain by one link!

30. ➤ Reattach the chain guide.

! NOTICE

Chain sizes 9x27 and 11.3x31:

- Insert the chain guide fastening screws with the thread-locking paste.
- The components must be free of oil and grease.

Tab. 23: Recommended thread-locking pastes

Manufacturer	Name	Properties
Weicon®	Weiconlock AN 302-42	Thread-locking paste, suitable for connections up to M36, breakaway torque min. 14 to 18 Nm
Henkel®	Loctite 243	Thread-locking paste, suitable for connections up to M20, breakaway torque min. 20 Nm

⚠ CAUTION

Risk of falling load

Check again:

- The chain must not be twisted between the chain guide and the hook block.

If assembly without a twisted chain is not possible, shorten the chain by one link!

31. ➤ Press the Lower button and move the hook block until just before the lowest position.

32. ➤ Fit the lift limiter including rubber buffer at the chain end to the chain box side.

! NOTICE

Load chain running out from the chain box

- Standard: fit the lift limiter to the third link before the chain end.
- Special version: The chain end of the load chain is attached to the electric chain hoist. The lift limiter must be mounted in such a way that the lift limiter lies on the floor of the chain box.

33. ➤ Insert the lift limiter into the chain box.

34. ➤ Attach the chain box.

35. ➤ Press the Lift button and allow the chain to go into the chain box.



At the same time, lubricate the entire length of the chain well.

6.3.5 Chain guide and downholder

Visual check

If there is visible wear on the chain cross and in the chain track, replace the chain guide.

If there are visible deformations and run marks, replace the downholder.

! NOTICE

When replacing the load chain, the chain guide and the downholder must always be replaced as well.

6.3.6 Rubber buffer

Visual inspection

Visually check all rubber buffers of the system for deformations, cracks and ruptures. Replace the rubber buffers if required.

6.3.7 Chain box

Visual check

Chain box fastening points

- Check the chain box fastening points for cracks.
- The bore must not be worn.

Chain box screw

- The securing nut must be present and screwed tight.
- The screw must not be bent.

Chain box frame

- The chain box frame must hang parallel to the electric chain hoist.
- The chain box frame must not be bent, the chain must be able to enter the chain box unobstructed.

Fabric chain box

- The fabric must not be ripped or stretched.
- If the chain box is stress-relieved by means of straps, the proper seating of the harness must be checked. The ratchet must be closed and undamaged.

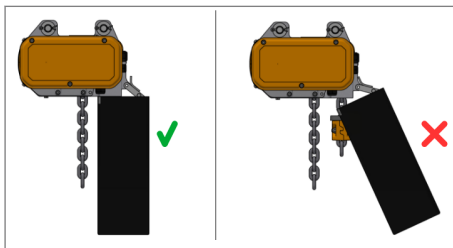

Fig. 69: Parallel chain box frame

Chain box Flip bag

- Check the firm seating of all screws on the retaining set. The sheets must not be bent.
- The chain box bag must be mounted correctly.
- The fabric must not be ripped or stretched.

Sheet metal chain box (depending on the design)

- Visually check welded seams for cracks.
- Check the completeness of the rivets.

6.3.8 Electric limit switch

Visual check

1. → Check whether the limit switch tappets are damaged or dirty.
2. → Check that both limit switch tappets protrude equally far from the housing.

Functional inspection

The functional inspection can only be carried out when the device is switched on.

CAUTION

Danger of injury to fingers

Carelessness during work entails a risk of injury by touching the chain.

Precautions:

- The tester must stand on the motor side of the electric chain hoist.
- The pendant control must be held in the hand to operate the electric chain hoist.
- Position the hook tackle or the hook block and the lift limiter so that they are at least 2 m from the limit switch tappets.
- Press the limit switch using a suitable tool (e.g. hammer handle).

1. → Switch on the electric chain hoist.

NOTICE

For 2-speed electric chain hoists, always select low speed.

Lift limit switch test

2. → Press the Lift button and press the lift limit switch tappet.
 - ➔ The electric chain hoist must stop immediately.

Lower limit switch test

3. → Press the Lower button and press the lower limit switch tappet.
 - ➔ The electric chain hoist must stop immediately.

6.3.9 Gear limit switch

Functional inspection

The functional inspection can only be carried out when the device is switched on.

CAUTION

Danger of injury

Carry out the test with extreme care.

Precautions:

- Observe the working environment.
- Pay attention to collision hazards.
- Use the lowest possible lifting speed.
- If necessary, have a second person assist in the test.

1. → Switch on the electric chain hoist.

Maintenance work > Brake

Lift operational limit switch test**Lower operational limit switch test****Lift emergency limit switch test****Lower emergency limit switch test**

2. → Push the Lift button and move the hook tackle or the hook block to the limit switch position.
 - ➔ The electric chain hoist must stop immediately.
3. → Push the Lower button and move the hook tackle or the hook block to the limit switch position.
 - ➔ The electric chain hoist must stop immediately.
4. → Bridging operational limit switches.
5. → Push the Lift button and move the hook tackle or the hook block to the limit switch position.
 - ➔ The electric chain hoist must stop immediately.
6. → Push the Lower button and move the hook tackle or the hook block to the limit switch position.
 - ➔ The electric chain hoist must stop immediately.
7. → Remove the bridge for operational limit switches.
8. → Check the functionality of the operational limit switch again.

! NOTICE

The emergency limit switches are not wired at the factory.

6.3.10 Brake**6.3.10.1 Simple brake****Maintenance****! WARNING****Risk of falling load**

Never open the brake or attempt to adjust the air gap.

The brake is maintenance-free.

! WARNING**Risk of falling load**

The brake must not come into contact with oil, grease or similar materials.

Oiled or greasy brakes must be replaced with new brakes.

Replacing the brake

Fig. 70: Brake replacement

If the brake has failed during functional inspection, the brake must be replaced.

1. → Remove the cap.
2. → Disconnect the brake cable.
 - 1 Motor shaft
 - 2 Fastening screw
 - 3 Complete brake
3. → Undo the fastening screws of the brake.
4. → Remove the worn brake.
5. → Slide the new brake onto the motor shaft.
6. → Fit the new operating brake with the integrated fastening screws. For the tightening torque for the fastening screws, see table ➔ Tab. 25 'Tightening torques' on page 72.
7. → Connect the brake cable according to the wiring diagram.
8. → Fit the cap.

6.3.10.2 Double brake

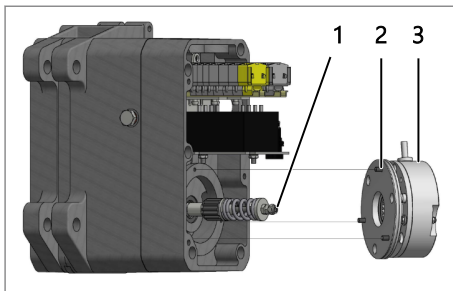
Maintenance

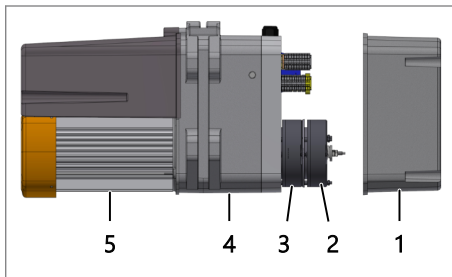

Fig. 71: Double brake

Replacing the double brake - model 03../...

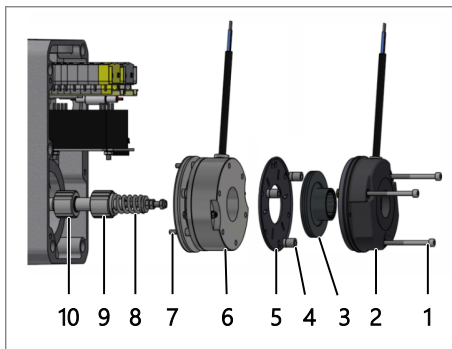

Fig. 72: Replacing the brake model 03../...

WARNING

Risk of falling load

Never open the brake or attempt to adjust the air gap.

The brake is maintenance-free.

WARNING

Risk of falling load

The brakes must not come into contact with oil, grease or similar materials.

Oiled or greasy brakes must be replaced with new brakes.

- 1 Cap
- 2 Safety brake
- 3 Operating brake
- 4 Housing
- 5 Motor

The double brakes consist of the operating and safety brakes. These two brakes act independently of one another. They are positioned in series.

If the brake has failed during functional inspection, the brake must be replaced.

1. Remove the cap.

2. Disconnect both brake connectors or brake cables.

- 1 Fastening screw
- 2 Safety brake
- 3 Rotor with brake pad
- 4 Spacer sleeves
- 5 Friction plate
- 6 Operating brake
- 7 Fastening screw
- 8 Motor pinion shaft
- 9 Safety brake hub
- 10 Operating brake hub

3. Undo the fastening screws of the safety brake.

4. Remove the safety brake, rotor, spacer sleeves and friction plate.

5. Undo the fastening screws of the operating brake.

6. Remove the operating brake.

7. Slide the new operating brake onto the brake hub.

8. Fit the new operating brake with the integrated fastening screws. For the tightening torque for the fastening screws, see table Tab. 25 'Tightening torques' on page 72.

9. Connect the friction plate onto the motor pinion shaft.

10. Mount the rotor on the safety brake hub.

11. Fix the three spacer sleeves between the friction plate and brake body of the new safety brake using the fastening screws.

12. Fit the new safety brake with the fastening screws. For the tightening torque for the fastening screws, see table Tab. 25 'Tightening torques' on page 72.

13. Connect both brake connectors or brake cables according to the wiring diagram.

14. Fit the cap.

Replacing the double brake - models 05./..., 07./..., 09./... and 11./...

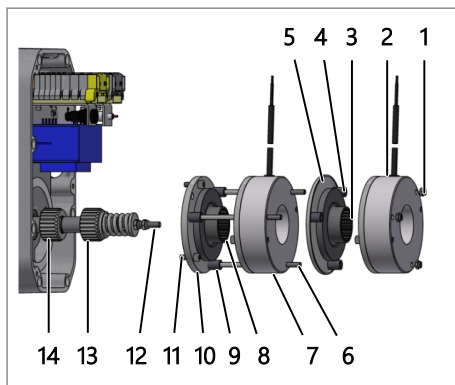

Fig. 73: Replacing the brake models 05./..., 07./..., 09./... and 11./...

1. ➔ Remove the cap.
2. ➔ Disconnect both brake connectors or brake cables.

- 1 Nuts
- 2 Safety brake
- 3 Rotor with brake pad
- 4 Spacer sleeves
- 5 Friction plate
- 6 Stay bolt
- 7 Operating brake
- 8 Rotor with brake pad
- 9 Spacer sleeves
- 10 Brake flange
- 11 Fastening screw
- 12 Motor pinion shaft
- 13 Safety brake hub
- 14 Operating brake hub

3. ➔ Undo the nuts of the safety brake.
4. ➔ Remove the safety brake, rotor, spacer sleeves and friction plate.
5. ➔ Remove the operating brake and rotor.
6. ➔ Undo the fastening screws of the brake flange.
7. ➔ Remove the brake flange with the stay bolts and spacer sleeves.
8. ➔ Slide the brake flange of the new operating brake onto the brake hub and mount with the fastening screws. For the tightening torque for the fastening screws, see table ➔ Tab. 25 'Tightening torques' on page 72.
9. ➔ Fit the stay bolts into the brake flange with the thread-locking paste.

Tab. 24: Recommended thread-locking pastes

Manufacturer	Name	Properties
Weicon®	Weiconlock AN 302-42	Thread-locking paste, suitable for connections up to M36, breakaway torque min. 14 to 18 Nm
Henkel®	Loctite 243	Thread-locking paste, suitable for connections up to M20, breakaway torque min. 20 Nm

10. ➔ Push the spacer sleeves onto the stay bolts.
11. ➔ Install the new rotor and the brake body of the operating brake on the stay bolts.
12. ➔ Mount the friction plate of the new safety brake on the stay bolts.
13. ➔ Push the spacer sleeves onto the stay bolts.
14. ➔ Mount the rotor on the safety brake hub.
15. ➔ Mount the new brake body of the safety brake on the stay bolts.
16. ➔ Fit the securing nuts on the stay bolts.
17. ➔ Connect both brake connectors or brake cables according to the wiring diagram.
18. ➔ Fit the cap.

Tab. 25: Tightening torques

Braking torque [Nm]	Screws	Torque [Nm]
4	3xM4	2.8
6	3xM5	5.5
9.6	3xM5	5.5

Braking torque	Screws	Torque
[Nm]	DIN EN ISO 4762	[Nm]
12	3xM5	5.5
18	3xM6	9.5
32	3xM6	9.5

6.3.10.3 Trolley brake Maintenance

WARNING

Brake failure

Never open the brake or attempt to adjust the air gap.

The brake is maintenance-free.

WARNING

Brake failure

The brake must not come into contact with oil, grease or similar materials.

Oiled or greasy brakes must be replaced with new brakes.

Replacing the brake

If the brake has failed during functional inspection, the brake must be replaced.

NOTICE

When using trolleys with two travel speeds, the entire motor must be replaced.

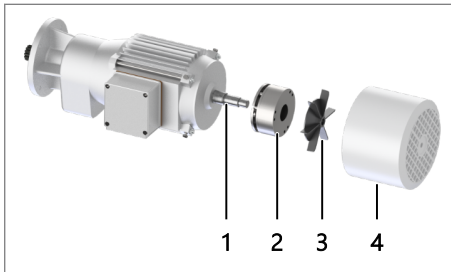





Fig. 74: Brake replacement

1.  Remove the cap and fan.

2.  Disconnect the brake cable.

- 1 Motor shaft
- 2 Complete brake
- 3 Fan
- 4 Cap

3.  Undo the fastening screws of the brake.

4.  Remove the worn brake.

5.  Slide the new brake onto the motor shaft.

6.  Fit the new brake with new fastening screws. Tightening torques of the screws according to the manufacturer's instructions.

7.  Connect the brake cable according to the wiring diagram.

8.  Install the fan and cap.

6.3.10.4 Manual ventilation

Optionally, the brake can be mechanically ventilated with a manual ventilation system. By actuating the manual release lever, the anchor plate is pulled against the magnet body. The brake is ventilated.

6.3.10.5 Functional inspection of the brake

The main power is on.

1. → Operation without load over a lifting distance of 1 m
 - Lower - Stop
 - Lift - Stop
 - Lower - EMERGENCY STOP
 - Lift - EMERGENCY STOP

➔ The movement must be stopped within one second.
2. → Operation with nominal load over a lifting distance of 1 m
 - Lower - Stop
 - Lift - Stop
 - Lower - EMERGENCY STOP
 - Lift - EMERGENCY STOP

➔ The movement must be stopped within one second.

! NOTICE
The load must not stop abruptly.

3. → Operation of the electric trolley without load over a route of 1 m
 - Travel right - Stop
 - Travel left - Stop

➔ The movement must be stopped.
4. → Travelling to the travel limit switches (optional) of the electric trolley without a load
 - Travel to right travel limit switch - Stop
 - Travel to left travel limit switch - Stop

➔ The movement must be stopped.

6.3.10.6 Fault correction

Fault description	Cause	Remedy
Brake does not vent, air gap is not zero	Interruption in the coil, shorted coil or accidental ground	Replace spring-loaded brake
	Wiring incorrect or defective	Compare with wiring diagram and correct
	Defective or incorrectly wired rectifier	<ul style="list-style-type: none"> ■ Compare bridge on rectifier with wiring diagram ■ Measure DC voltage at terminal 5-6 during operation ■ Replace the rectifier in case of deviation
	Air gap too great	Replace spring-loaded brake

! NOTICE
If the rectifier fails repeatedly, the brake is to be replaced, even if no shorted coil or accidental ground can be measured. The fault may only occur when heated.

i *Technical data of the brake*
The technical data of the brake is specified on the stickers on the magnetic body of the brake.

6.3.11 Clutch

6.3.11.1 Structure

The safety slip clutch is located between the drive and the brake. The brake acts directly on the load via a positive connection in the gear without loading the clutch.

Even if the clutch is highly worn, an uncontrolled drop of the load is not possible, since the load can be kept in any position with the brake.

The slip clutch operates as a dry clutch using an asbestos-free coating.

⚠ CAUTION

The slip clutch provides directly acting overload protection and must not be intentionally triggered in operation.

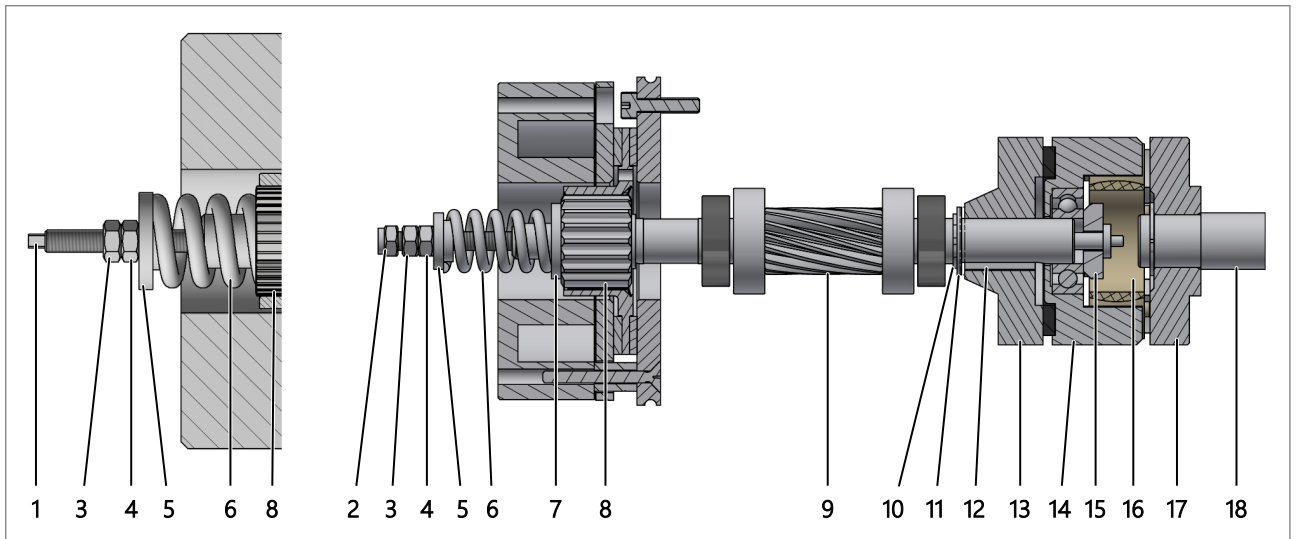

Fig. 75: Structure of the clutch – variants

- | | |
|-------------------------------|--|
| 1 Flat end draw bar | 10 Retaining ring (if fitted) |
| 2 Draw bar with retaining nut | 11 Support washer (if fitted) |
| 3 Lock nut | 12 key |
| 4 Pressure nut | 13 Coupling disc |
| 5 Spring seat | 14 Drive disc with clutch lining and bearing |
| 6 Pressure spring | 15 Pressure piece |
| 7 Washer | 16 Sprocket |
| 8 Brake hub | 17 Coupling hub |
| 9 Pinion shaft | 18 Motor stub shaft |













6.3.11.2 Replacing the clutch

The clutch must be replaced if it is no longer set in such a way that the electric chain hoist can safely lift 1.1 times the nominal load and/or if it does not slip before reaching 1.6 times the nominal load.

Preparations:

- Disconnect the electric chain hoist from the power supply.
- Place the electric chain hoist on a stable and secure workplace.
- Position the new clutch assembly close at hand.

1. → Remove the control cap.
2. → Disconnect the motor cable, keeping the rubber seal in a safe place.
3. → Remove the motor with the coupling hub.
 - ➔ The coupling hub on the motor stub shaft does not need to be replaced.
4. → Remove the brake cap.
5. → Hold the head of the draw bar on the motor side in place using the special bit and remove all nuts and the spring seat, pressure spring and washer (if fitted) from the draw bar on the brake side.

6.  Pull out the draw bar and remove the old clutch assembly.
7.  Remove the key, washer and retaining ring if present from the pinion shaft.
8.  Install the new clutch assembly in the reverse order.
9.  Insert the motor cable into the groove on the housing.
10.  Secure the motor cable in the groove on the housing using the rubber seal.
11.  Install the motor.
12.  Fit the control cap.
13.  Suspend the electric chain hoist.
14.  Connect to the power supply.
15.  Adjust the clutch → *Chapter 6.3.11.3 'Adjusting the clutch' on page 76.*
16.  Fit the brake cap.
17.  Document the replacement of the clutch in the inspection book.

6.3.11.3 Adjusting the clutch

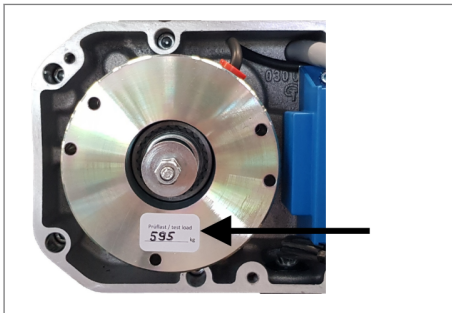

Fig. 76: Test load sticker

Setting with test load (dynamic test)

The slip clutch is factory-set with a test load. A sticker with the test load used in the factory is attached near the clutch.





! NOTICE



If the load is measured with an adjusting device against a fixed point, the load value to be read for the clutch setting when the clutch is slipping is approx. 30 % higher than the value of the nominal load. The slip time must not exceed 2–3 seconds.

! NOTICE

The clutch setting in electric chain hoists with two lifting speeds takes place at the higher speed (main hoist).

Test load = 1.1x nominal load

1.  Secure the test load to the load hook.
2.  Press "Lift" on the pendant control of the electric chain hoist.
 - ➔ Check that the test load is raised.
3.  Loosen the lock nut (3).
4.  Hold the draw bar securely with pliers (1) or the retaining nut with a ring wrench (2).
5.  Rotate the pressure nut (4) to the right, so that the load is just being lifted.
 - ➔ The coupling torque increases.

or
6.  Rotate the pressure nut (4) to the left so that the load is just being lifted.
 - ➔ The clutch torque is reduced.
7.  Lock the coupling setting with the lock nut (3).
8.  Check the coupling setting again by lifting the nominal load.

Adjustment with sliding force tester (static test)

! NOTICE

Only suitable test equipment may be used.





Read and the operating instructions of the test device carefully before use and observe them.



⚠ CAUTION

Risk of crushing

Crushing of fingers

- Only hold the sensor by the handle.
- Wear protective gloves.

1.  Secure the tester to the chain above the load hook.
2.  Press the "Lift" button on the pendant control of the electric chain hoist and gently move the testing device against the housing of the electric chain hoist.
 - ➔ Check whether the test device shows the measured value = 1.3 times the nominal load.
3.  Loosen the lock nut (3).
4.  Hold the draw bar securely with pliers (1) or the retaining nut with a ring wrench (2).
5.  Rotate the pressure nut (4) to the right, so that the load is just being lifted.
 - ➔ The coupling torque increases.

or
6.  Rotate the pressure nut (4) to the left so that the load is just being lifted.
 - ➔ The clutch torque is reduced.
7.  Lock the coupling setting with the lock nut (3).
8.  Check the coupling setting again by lifting the nominal load.

6.3.11.4 Tests

Initial commissioning test

 *The clutch is factory-set in accordance with the contractual agreement. The load capacity (WLL) specified on the type plate is what can be lifted safely.*

During the initial commissioning of the electric chain hoist, 1.1 times the nominal load must be raised safely and reliably. In addition, the trigger limit of the clutch must be checked. ➔ *Chapter 6.3.11.5 'Trigger limit test' on page 78*

Recurring test of the clutch

During the recurring test, it must be checked whether the electric chain hoist reliably lifts the test load. In addition, the trigger limit of the slip clutch must be checked.

 *Test load for recurring test = nominal load or a load close to nominal load*

Implementation of the test

1.  Check whether the nominal load is lifted safely.

2. → Check the trigger limit with appropriate test equipment.

! NOTICE

The trigger limit should be approx. 1.3 times the nominal load.

3. → Check again whether the nominal load is lifted.
 - ➔ In the event of faults, the setting of the slip clutch is to be repeated and the trigger limit of the slip clutch is to be checked again.
4. → Log the setting value in the test book.

6.3.11.5 Trigger limit test

The trigger limit of the slip clutch should be between 1.3 times and 1.4 times the nominal load. A load of 1.6 times the nominal load may not be lifted.

i *If test weights greater than the nominal load are not available for the recurring test, the trigger limit of the slip clutch can also be tested with a suitable test device.*

Test using a slip test device

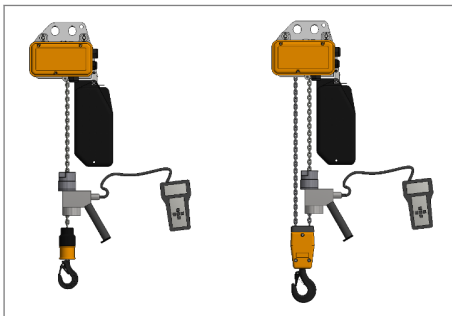

Fig. 77: Slip test device arrangement

1. → Secure the tester to the chain above the load hook.

! NOTICE

Only suitable test equipment may be used.

Read the operating instructions of the test device carefully before use and observe them.

! CAUTION

Risk of crushing

Crushing of fingers

- Only hold the sensor by the handle.
- Wear protective gloves.

2. → Press "Lift" on the pendant control of the electric chain hoist.
3. → Start the force transducer of the test device until the chain is blocked.
 - ➔ Record the measurement value
4. → Repeat the measurement several times.

i *It is recommended to carry out several measurements. The first measured value is usually higher, since the slip clutch heats up when slipping and the trigger load of the slip clutch drops.*

5. → Assess the measurements.
 - ➔ Determine whether the clutch must be adjusted.

6.3.12 Motor

Motor ventilation test

i *A damaged or non-functioning fan wheel significantly affects the duty cycle of the motor.*

Performance

1. → Inspect the fan cap.
 - ■ The fan cap must not be damaged.
 - The fan wheel must not grind against the fan cap.
2. → Inspection of the fan wheel
 - ■ Check that no fan wheel fins are damaged.

Replacing the lift motor

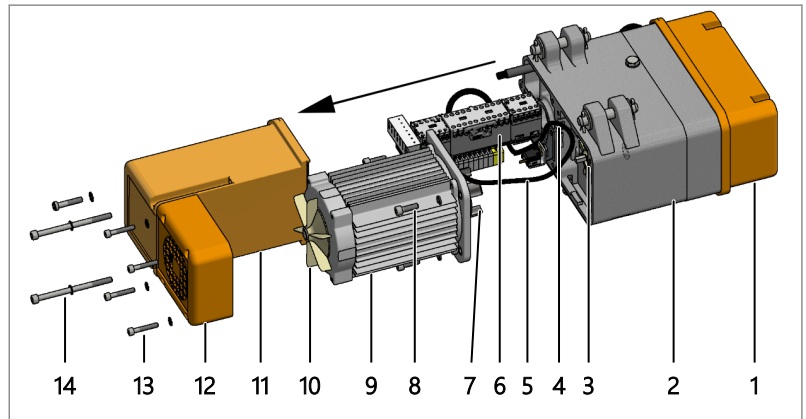

Fig. 78: Replacing the motor

- 1 Brake side cap
- 2 Housing
- 3 Sprocket
- 4 Recess in the housing
- 5 Motor cable
- 6 Control
- 7 Claw clutch
- 8 Screws and spring washers
- 9 Lift motor
- 10 Fan wheel
- 11 Control cap
- 12 Fan cap
- 13 Screws and spring washers
- 14 Screws and spring washers

Disassembly of lift motor

1. → Undo the control cap screws and remove the control cap **in the direction of the arrow**.
2. → Undo the screws on the fan cap and remove the fan cap.
3. → Unplug the motor cable from the control terminal block.



Electric chain hoists with direct controls

By way of derogation, for electric chain hoists with direct controls, the motor cable must be disconnected in the terminal compartment on the brake side and pulled through the housing to the motor side.

4. → Loosen the motor screws and remove the lift motor from the gear.



CAUTION

Short circuit

The motor cable must not be crushed or damaged.

Assembly of a new lift motor

Requirements:

- Valid wiring diagram
- New lift motor with mounted fan wheel and clutch

- Sealing rubber for housing recess
 - New screws and spring washers for motor attachment
1. → Clean the housing and motor flange, in particular remove residues from the old sealing compound.
 2. → Apply new sealing compound to the housing.
 3. → Position the lift motor on the centring of the housing.

Make sure that

- the motor cable is routed laterally in the recess of the housing.
- the sealing rubber seals the recess in the housing completely.
- the claws of the clutch engage with the sprocket.

! NOTICE

The claws of the clutch engage with the sprocket by carefully rotating the fan wheel.

! CAUTION

Short circuit

The motor cable must not be crushed or damaged.

4. → Install the lift motor on the housing using screws and spring washers.
5. → Connect the motor cable to the terminal block according to the wiring diagram.

Check again that

- the motor cable is not pinched or damaged.
- that the sealing rubber seals the recess in the housing completely.



Electric chain hoists with direct controls

By way of derogation, for electric chain hoists with direct controls, the motor cable must be pulled through the housing to the terminal compartment on the brake side and clamped there in accordance with the wiring diagram.

6. → Install the control cap.
7. → Fit the fan cap.
8. → Press the Lift button.
 - ➔ If the load moves downwards, switch wires L1 and L2.

! WARNING

Disconnect the system from power before doing this.

9. → Document the replacement of the motor in the inspection book.



It is not necessary to readjust the clutch when replacing the lift motor. Only one test load with the nominal load is required.

Replacement of travelling motor

! NOTICE

The motor with side panel must be replaced by two people.

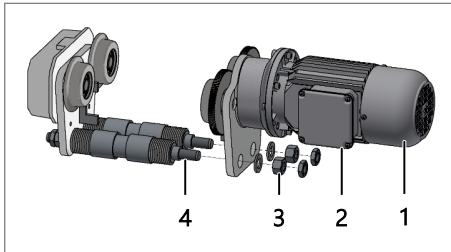

Fig. 79: Replacing the motor with the side panel

- 1 Travelling motor including side panel
- 2 Terminal box
- 3 Connectors
- 4 Suspension bolt

1. → Disconnect the cable in the terminal box. If necessary, disconnect the contactor control cable between the trolley and electric chain hoist.
2. → Remove the electric chain hoist.
3. → Release the connectors and remove the trolley motor including the side panel from the suspension bolts.

⚠ CAUTION

Danger of injury

Secure the non-powered side panel against falling.

4. → Install the new motor including the side panel and install it using the connectors.
5. → Lubricate the toothing of the rollers on the powered side panel. → *Further information on page 82*
6. → Mount the electric chain hoist.
7. → Connect the cable in the terminal box according to the wiring diagram.
8. → Press the travel direction button.
 - ➔ If the trolley moves in the incorrect direction, switch wires L1 and L2.

⚠ WARNING

Disconnect the system from power before doing this.

9. → Document the replacement of the motor in the inspection book.
10. → Mount the chain hoist, and if necessary, connect the contactor control cable between the trolley and the electric chain hoist using the wiring diagram.

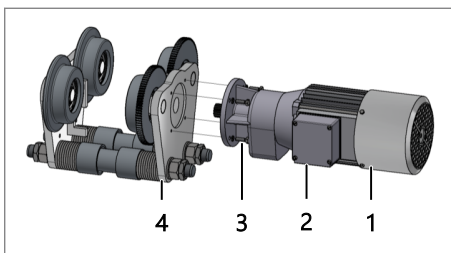

Fig. 80: Replacing the motor

- 1 Travelling motor (gearmotor)
- 2 Terminal box
- 3 Connectors
- 4 Trolley side panel



For trolleys with a gearmotor, only the gearmotor needs to be replaced. The electric chain hoist does not need to be disassembled.

6.3.13 Lubrication

6.3.13.1 Lubricating the load chain

! NOTICE

Prior to initial commissioning and during operation of the electric chain hoist, the chain links must be lubricated over the entire chain length with a penetrating oil.

1. → The chain must be cleaned before repeated lubrication.

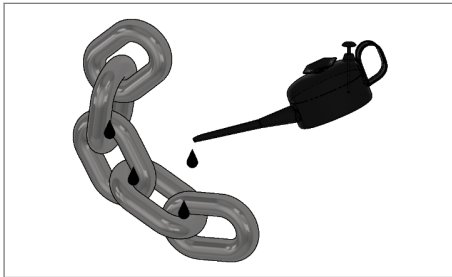

Fig. 81: Lubricating the chain

2. → Lubricate the chain without load.

i Lubricate the chain links above all at the points of contact between the chain links.

3. → Lubricate the chain over the entire length of the chain.

! NOTICE

Lubricate the chain in the chain box as well.

! NOTICE

The amount of lubricant and the frequency of lubrication must be adapted to the operating conditions.

The chain must be lubricated at least every third month.

Use dry lubricants if the electric chain hoist is operated under conditions causing high wear (sand, emery, etc.)

The following lubricants are recommended depending on the operating conditions:

Tab. 26: Chain lubricant

Supplier	Name	Remarks
Tectrol®	Kettenöl K50	
Tectrol®	Tectrol Multi Spray XL	Dry lubricant
Tectrol®	Food Kettenspray	Food industry
Klüber®	Klüberoil CA 1-460	
Klüber®	Klüberoil 4UH 1-1500	Food industry
Castrol®	Optimol Viscogen KL300	
Fuchs Lubritech®	Ceplattyn 300	Dry lubricant
Fuchs Lubritech®	Stabylan 2001	
Fuchs Lubritech®	Stabylan 5006	
Fuchs Lubritech®	Decordyn 350	
Fuchs Europe®	Renolit SO-GFB	Grease
Klüber®	Microlube GB 00	Grease

6.3.13.2 Lubricating the trolley

! NOTICE

Grease the pinion and tothing of the rollers of the electric trolleys:

- **Before initial commissioning**
- After approx. 10000 travel cycles or one year under normal operating conditions
- In the case of harsh operating conditions at short intervals

The following lubricants are recommended:

Tab. 27: Lubricants for tothing

Supplier	Name
Tectrol®	Tectrol special grease LX 2
Fuchs Europe®	Renolit Duraplex EP3
Fuchs Lubritech®	Lagermeister LX EP2

6.3.13.3 Gear lubrication

i The gear is filled with gear oil at the factory.
The gear is lubricated for life.

An oil change is required:

- upon overhaul of the electric chain hoist
- in the case of visible leaks
- after each opening of the gear

! NOTICE

It must be ensured that the gear housing contains the correct amount of gear oil. This requires a complete oil change.

! WARNING

Switch the electric chain hoist off.
Remove the attachments if required.
Place an oil collection pan.

Oil change

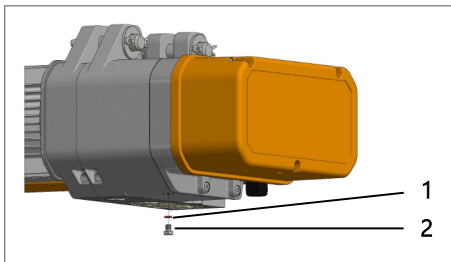

Fig. 82: Draining the oil

- 1 Seal or toothed washer
 - 2 Oil plug
1. → Remove oil plug and seal.
 - ➔ Drain the oil completely.
 2. → Fill in new oil in the specified quantity.
 3. → Close the oil plug again with a seal.
 4. → Dispose of the used oil in an environmentally sound manner.

! NOTICE

Observe national and regional regulations.

Tab. 28: Quantities of oil

Type	Volume [ml]	Volume [gal]
03../...	175	0.046
05../... - 07../...	350	0.092
09../... - 11../...	525	0.139

The following types of oil may be used:

Tab. 29: Oil types

Supplier	Name	Remarks
Tectrol [®]	Tectrol Gear CLP 220	
Tectrol [®]	Tectrol Food CLP 220	Food industry
Fuchs Europe [®]	Renolin CLP 220	
Mobil [®]	Mobil SHC 630	
Shell [®]	Omala 220 S2 G220	
Total [®]	Carter EP 220	
Castrol [®]	Alpha SP 220	

! NOTICE

Mineral oil with a viscosity of 220 mm²/s at 40 °C should be used.

6.3.13.4 Lubricating the load and suspension hooks

NOTICE

Lubricate the bearing of the hook and the chain sprocket:

- After approx. 20000 lift cycles or one year under normal operating conditions
- In the case of harsh operating conditions at short intervals



The following lubricants are recommended:

Tab. 30: Bearing lubricants

Supplier	Name
Tectrol [®]	Tectrol special grease LX 2
Fuchs Europe [®]	Renolit Duraplex EP3
Fuchs Lubritech [®]	Lagermeister LX EP2

6.3.14 Control

6.3.14.1 Checking the control

1.  Check the EMERGENCY STOP function.
2.  Check the limit switch function.
3.  Check the lift/lower function (both speeds).
 - ➔ The load must move in the direction selected on the pendant control.

6.3.14.2 Opening the terminal compartment

Maintenance work on the electrical system may only be carried out by qualified electricians.

Local regulations apply.

WARNING

Electric shock

Maintenance work may only be carried out on the electric chain hoist when it is in an unloaded and voltage-free state. Switch OFF the main switch and secure it against unauthorised reactivation. Pressing the EMERGENCY STOP button does not replace switching off the system at the main switch.

After opening the terminal compartment, the following checks must be carried out at the control and in the terminal compartment:

Visual inspection

- Terminal compartment clean and dry
- No contact erosion, no traces of powder
- Cables routed correctly
- No loose or pinched wires
- No damaged insulation

CAUTION

Damaged parts must be replaced before continuing operation.

! NOTICE

When replacing the control unit, you must remove the old sealing compound and seal the sealing surface of the control unit console with new sealing compound. You must use a permanent plastic motor and housing sealing compound.

Before reassembling the cap, check the seal for integrity.

6.3.14.3 Control arrangement

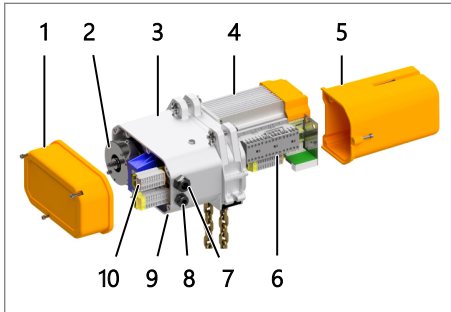

- 1 Brake side cap
- 2 Brake
- 3 Gear housing
- 4 Motor
- 5 Control cap
- 6 Motor side control
- 7 Trolley cable gland
- 8 Power supply cable gland
- 9 Control cable gland (not visible)
- 10 Brake side control

Fig. 83: Example of contactor control

6.3.14.4 Direct control



The motor is controlled directly via the pendant control.

Direct control 3 phases

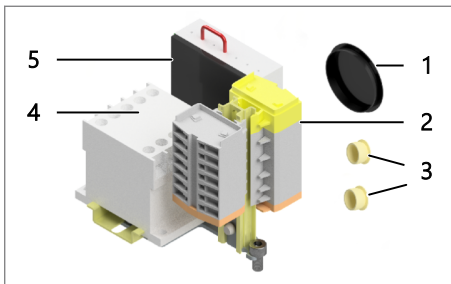

The control is located under the brake cap.

- 1 Cover plug
- 2 Terminal block
- 3 Cover plug
- 4 Contactor (only for two-speed electric chain hoists)
- 5 Rectifier

Fig. 84: Direct control 3 phases

6.3.14.5 Contactor control

By default, the contactor control has 24 V AC, but other control voltages are possible.

Contactor control, 3-phase

The control is in two parts and is arranged under the control cap next to the lift motor and under the brake cap.

Troubleshooting and fault correction

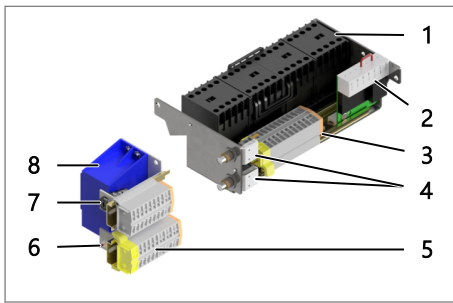

- 1 Contactors
- 2 Rectifier
- 3 Terminal block
- 4 Electric limit switch
- 5 Terminal block
- 6 Secondary fuse
- 7 Primary fuse
- 8 Transformer

Fig. 85: Contactor control, 3-phase

Contactor control 1 phase

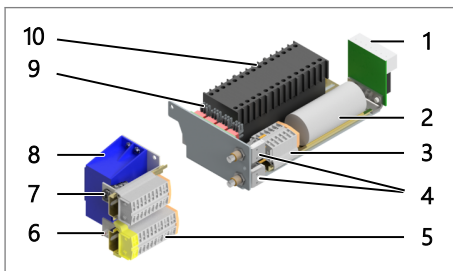

- 1 Rectifier
- 2 Capacitor
- 3 Terminal block
- 4 Limit switch
- 5 Terminal block
- 6 Secondary fuse
- 7 Primary fuse
- 8 Transformer
- 9 Electronics starter
- 10 Contactors

Fig. 86: Contactor control 1 phase

The control is in two parts and is arranged under the control cap next to the lift motor and under the brake cap.

6.3.14.6 Circuit board control

The control is in two parts and is arranged under the control cap next to the lift motor and under the brake cap.

! NOTICE

The individual components of the board are not interchangeable.

! DANGER

Electric shock / fire risk

The distance of 6 mm between the circuit board and the console must not be reduced.

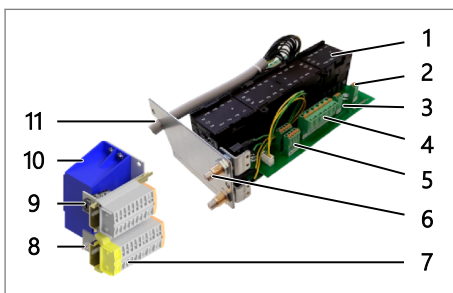

- 1 Contactors
- 2 Terminal for PE protective conductor
- 3 Terminal for temperature sensor
- 4 Terminals for motor phases
- 5 Terminals for star point
- 6 Electric limit switch
- 7 Terminal block
- 8 Secondary fuse
- 9 Primary fuse
- 10 Transformer
- 11 Connecting cable

Fig. 87: Circuit control 3 phases

6.4 Troubleshooting and fault correction

! WARNING

Testing and repair work may only be carried out by competent persons.

 **WARNING**

Dangerous voltage occurs at the electric chain hoist and the connections to the components. Risk of death or serious injuries (disability) when working on closed circuits. Before performing any maintenance work on the device, turn off the power supply and disconnect the device from the power supply. The circuit breaker must be locked in the off position and this must be marked. It must also be secured against unauthorised reactivation.

Fault description	Cause	Remedy
Electric chain hoist does not work	Power interruption	Check the main power switch, switches, fuses and connections on all three phases of the power supply/cable.
	Incorrect voltage or frequency	Check the voltage and frequency of the power supply and compare them with the specifications on the type plate of the electric chain hoist.
	Electric chain hoist overloaded, clutch slipping	Reduce the load down to the nominal load (see type plate).
	Motor overheated and thermal circuit breaker tripped	See "Motor or brake overheated" problem.
	Incorrect wiring, loose or broken wires in the electric system of the electric chain hoist	Cut the power supply, check the cable connections of the control and the pendant control of the electric chain hoist
	Brake does not open	Check the resistance of the brake coil. Replace the brake if necessary. Check the input voltage on the rectifier (terminals 1 and 2). Check the output voltage of the rectifier (terminals 5 and 6). Replace the rectifier if required. Check the contacts of the contactors. Replace any faulty contactor.
Electric chain hoist (still) does not work	Faulty contactors	Check the coil for wire break or short circuit. Check all connections of the controller. Check the continuity of the contactors' switching contacts. Replace defective parts.
	EMERGENCY STOP pressed on the pendant control	Turn the EMERGENCY STOP button clockwise to unlock the control.
	Defect in the control transformer	Check the control transformer for signs of possible overheating. Disconnect the control transformer and check for open winding.
	Defective primary or secondary fuse	Replace fuse
	Motor burned out	Replace the motor and all damaged parts.
Load moves in the wrong direction	Power supply is clamped in reverse direction	Swap 2 of the 3 wires of the power supply (see chapter "Mains connection").
	Incorrect electrical wiring	Compare with wiring diagram and check all connections.
Motor or brake overheated	Incorrect voltage or frequency	Compare the voltage and frequency of the power supply with the specifications on the type plate of the electric chain hoist. Set the voltage and frequency specified on the type plate. Replace the device if required.
	Brake does not open	Check the brake gap. Check brake coil, brake cables and rectifier. Replace if required.

Troubleshooting and fault correction

Fault description	Cause	Remedy
Motor or brake overheated	Extreme external heat	At temperatures above 40 °C, the operating time and frequency must be reduced in order not to overload the motor thermally. Special precautions must be taken to ventilate the electric chain hoist or to shield it from the heat.
Electric chain hoist lifts does not lower	Incorrect operating mode (jog mode, switch operations per hour)	Check the circuit for broken contacts. Check the lowering limit switch.
	Cable/wire breakage in the control cable	Check the passage of each wire in the cable. If a wire is broken, replace the entire control cable.
	Faulty switch inserts in the pendant control	Check the electrical continuity. Check the electrical connections. Replace defective parts.
	Faulty contactors	Check the coil for wire break or short circuit. Check all connections of the controller. Check the continuity of the contactors' switching contacts. Replace the contactors if necessary.
	Chain jammed	Verify that the chain can enter the chain box smoothly. Check whether the chain is knotted, and remove knots. Replace the chain and chain guide in case of visible damage.
Electric chain hoist lowers but does not lift	Electric chain hoist overloaded	Reduce the load down to the nominal load.
	Undervoltage in the power supply of the electric chain hoist	Determine the cause of the undervoltage and adjust the voltage to that specified on the type plate. Measure the voltage at the input terminals of the electric chain hoist.
	Incorrect operating mode (jog mode, switch operations per hour)	Check the circuit for broken contacts. Check the lifting limit switch.
	Cable/wire breakage in the control cable	Check the passage of each wire in the cable. If a wire is broken, replace the entire control cable.
	Faulty switch inserts in the pendant control	Check the electrical continuity. Check the electrical connections. Replace defective parts.
	Faulty contactors	Check the coil for wire break or short circuit. Check all connections of the controller. Check the continuity of the contactors' switching contacts. Replace the contactors if necessary.
	Worn slip clutch	Check the clutch setting or replace the clutch.
	Chain jammed	Verify that the chain can enter the chain box smoothly. Check whether the chain is knotted, and remove knots. Replace the chain and chain guide in case of visible damage.
Electric chain hoist does not lift the nominal load or does not lift at the correct lifting speed	Electric chain hoist overloaded	Reduce the load down to the nominal load.
	Undervoltage in the power supply of the electric chain hoist	Determine the cause of the undervoltage and adjust the voltage to that specified on the type plate. Measure the voltage at the input terminals of the electric chain hoist.
	Worn slip clutch	Check the clutch setting or replace the clutch.

Reaching the end of the theoretical service life > Calculation of remaining service life

Fault description	Cause	Remedy
Electric chain hoist does not lift the nominal load or does not lift at the correct lifting speed	Chain jammed	Verify that the chain can enter the chain box smoothly. Check whether the chain is knotted, and remove knots. Replace the chain and chain guide in case of visible damage.
Too much trailing distance when stopping	Brake worn	Check the brake air gap. Replace the brake if necessary.
	Excessive load	Reduce the load down to the nominal load.
Electric chain hoist movement is jerky, with intermittent failures	Defective contactors	Check for burned contacts in the contactors. Replace if required.
	Loose contact in the circuit	Check all cables and connecting terminals for poor connections. Replace if required.
	Faulty limit switch contact	Check and measure the limit switch. Check the mechanical function of the limit switch tappets. Replace the limit switch if required.
	Defective cable or wire breakage in the pendant control	Check the wiring of the pendant control for interruptions/faults. Replace the entire pendant control if the interruptions cannot be resolved

6.5 Reaching the end of the theoretical service life

6.5.1 Remaining service life

The electric chain hoist is dimensioned according to FEM 9.511. The remaining service life according to FEM 9.755 must be determined and documented annually.

6.5.2 Calculation of remaining service life

The remaining service life is the difference between theoretical and actual service life.

The theoretical service life can be determined from the driving mechanism group of the electric chain hoist. The driving mechanism group is to be defined for each electric chain hoist and can be found in the type plate and test book.

Tab. 31: Driving mechanism group in accordance with FEM 9.755

FEM/ISO	1Bm/M3	1Am/M4	2m/M5	3m/M6	4m/M7
Theoretical service life D [h]	400	800	1600	3200	6300

The actual use S (= used up portion of the theoretical useful life in the assessment period) must be determined annually and added up (see test book).

Remaining service life:

$$D - S = \dots\dots\dots - \dots\dots\dots = \dots\dots\dots \text{h}$$



The ratio of actual use to theoretical use (S/D) must be ≤ 1.

Harmonised standards

! NOTICE

If the end of the theoretical service life has been reached or is reached before the end of the following test period, the electric chain hoist and its components must be subjected to a general overhaul or disposed of in an environmentally friendly manner.

6.6 Disassembly and disposal

When disassembling the electric chain hoist and its components, observe the following:

! WARNING

Set all switches to OFF.

Disconnect the power connector.

Allow the motor to cool.

Carry out all dismantling in the reverse order as for assembly (see chapters Assembly and Maintenance).

After proper disassembly, the components made of metal, plastics and rubber must be recycled separately. Electronics waste, lubricants and auxiliary materials must be disposed of separately by specialist companies.

National and regional provisions must be complied with.

7 Directives and standards applied**7.1 General validity EU**

The assembly, commissioning, testing and maintenance of hoists in the Federal Republic of Germany or in EU countries are based essentially on the following regulations and the information in these operating instructions.

The manufacturer assume no liability for violations of safety regulations and the operating instructions.

In other countries, the applicable national regulations must be observed.

The following directives, standards and technical specifications have been applied.

7.2 European Directives

2006/42/EG	Machinery Directive
2014/30/EU	EMC Directive
2014/35/EU	Low Voltage Directive

7.3 Harmonised standards

The following harmonised standards have been applied:

EN ISO 12100:2010	Safety of machinery
EN 14492-2:2006+A1:2009	Cranes – Power driven winches and hoists
EN 818-7:2002+A1:2008	Chains for hoists, grade T
EN ISO 13849-1:2023	Safety-related parts of controls systems – General principles for design
EN 60034-1:2010	Rotating electrical machines – Rating and performance
EN IEC 60034-5:2020	Rotating electrical machines – Degrees of protection provided by the integral design
EN 60204-1:2018	Electrical equipment of machines – General requirements
EN 60204-32:2008	Electrical equipment of machines – Requirements for hoisting machines

EN 60529:1991+A1:2000+A2:2013	Degrees of protection provided by enclosures (IP code)
EN 60947-1:2021	Low-voltage switchgear, general specifications
EN IEC 61000-6-2:2019	Electromagnetic compatibility – Immunity standard for industrial environments
EN IEC 61000-6-3:2021	Electromagnetic compatibility – Electromagnetic interference for residential, commercial and small business environments
EN IEC 61000-6-4:2019	Electromagnetic compatibility – Electromagnetic interference for industrial environments
EN IEC/IEEE 82079-1:2020	Preparation of information for use of products, layout, content and presentation

7.4 Standards and technical specifications

The following national standards and technical specifications have been applied:

FEM 9.511:1986	Rules for the design of series lifting equipment – Classification of mechanisms
FEM 9.683:1995	Selection of lifting and travel motors
FEM 9.751:1998	Power-driven series hoists mechanisms, safety
FEM 9.755:1993	Measure for achieving safe working periods

8 Example declaration of conformity

LIFTKET Hoffmann GmbH
 Dresdener Straße 66-68, 04808 Wurzen, Germany



Declaration of Conformity



(Machine Directive 2006/42/EC supplement II 1 A)

Herewith the manufacturer declares that the electric chain hoist meets the appropriate requirements of the Machine Directive 2006/42/EC.

Model
 Serial number electric chain hoist

The protection targets of the Low Voltage Directive 2014/35/EU were observed in accordance with supplement I, no. 1.5.1 of the Machine Directive 2006/42/EC.

The conformity with the rules of the following further EC-Directives will be declared:

2014/30/EU Directive relating to electromagnetic compatibility

The following harmonised regulations are applied:

EN ISO 12100: 2010	Safety of machinery
EN 60204-32: 2008	Electrical equipment of machines; Requirements for hoisting machines
EN 14492-2: 2006 + A1: 2009	Cranes; Power driven hoists
EN 818-7: 2002 + A1: 2008	Fine tolerance hoist chain, Grade T

The following national regulations and technical specifications are applied:

FEM 9.511: 1986	Classification of mechanisms
FEM 9.751: 1998	Power driven series hoist mechanisms - Safety

The relevant technical documents according to the Machine Directive 2006/42/EC supplement VII 1 A are issued and will be provided on reasonable request to national authorities.

Authorised person of technical documents:
 LIFTKET Hoffmann GmbH, Dresdener Straße 66-68, 04808 Wurzen, Germany

The type was certified by:	TÜV Rheinland Industrie Service GmbH	Test certificate number
	Burger Chaussee 9	
	03044 Cottbus	
	Germany	

Wurzen, (Date)

(Signature)

(Name)
 Technical Manager

9 Example declaration of incorporation

LIFTKET Hoffmann GmbH
 Dresdener Straße 66-68, 04808 Wurzen, Germany



Declaration of Incorporation for partly completed machinery
 (Machine Directive 2006/42/EC supplement II 1 B)

Herewith the manufacturer for partly completed machinery (electric chain hoist) declares, that the use is not allowed until it has been certified that - as appropriate - the machinery which the electric chain hoist has been installed into meets the regulations of the Machine Directive 2006/42/EC.

Model
 Serial number electric chain hoist

The following essential health and safety requirements relating to the supplement I of the Machine Directive 2006/42/EC are applied and observed:

1.1 General	1.1.1; 1.1.2; 1.1.3; 1.1.5; 1.1.6
1.2 Control systems	1.2.1; 1.2.2; 1.2.3; 1.2.4; 1.2.4.1; 1.2.4.2; 1.2.4.3; 1.2.6
1.3 Protection against mechanical hazards	1.3.2; 1.3.3; 1.3.4; 1.3.7; 1.3.9
1.5 Risks due to other hazards	1.5.1; 1.5.4; 1.5.6; 1.5.8; 1.5.11
1.6 Maintenance	1.6.1; 1.6.3; 1.6.4
1.7 Information	1.7.1; 1.7.2; 1.7.3; 1.7.4; 1.7.4.1; 1.7.4.2; 1.7.4.3
4.1 General	4.1.1; 4.1.2; 4.1.2.3; 4.1.2.4; 4.1.2.6; 4.1.3
4.2 Requirements for machinery whose power source is other than manual effort	4.2.1; 4.2.2
4.3 Information and markings	4.3.3
4.4 Instructions	4.4.2

All relevant essential health and safety requirements relating to the Machine Directive 2006/42/EC are applied and observed up to the interfaces described in the order confirmation, in the operating instructions and in the wiring diagram.

The conformity with the rules of the following further EC-Directives will be declared:

2014/30/EU Directive relating to electromagnetic compatibility

The following harmonised regulations are applied:

EN ISO 12100: 2010	Safety of machinery
EN 60204-32: 2008	Electrical equipment of machines; Requirements for hoisting machines
EN 14492-2: 2006 + A1: 2009	Cranes; Power driven hoists
EN 818-7: 2002 + A1: 2008	Fine tolerance hoist chain, Grade T

The following national regulations and technical specifications are applied:

FEM 9.511: 1986	Classification of mechanisms
FEM 9.751: 1998	Power driven series hoist mechanisms - Safety

The relevant technical documents according to the Machine Directive 2006/42/EC supplement VII 1 B are issued and will be provided on reasonable request to national authorities.

Authorised person of technical documents:
 LIFTKET Hoffmann GmbH, Dresdener Straße 66-68, 04808 Wurzen, Germany

The type was certified by: TÜV Rheinland Industrie Service GmbH Test certificate number
 Bürger Chaussee 9
 03044 Cottbus
 Germany

Wurzen, (Date)

(Signature)

(Name)
 Technical Manager