



Round Grab RG

Due to the ultra slim design the grab can be used in very slender trenches.

Exchangeable gripping elements to prevent coated or stoneware pipes from damage.

- ▶ With adjustable opening width by spring loaded bolts.

Standard Specifications:

- ▶ With crane eye for attaching to crane hook.
- ▶ With automatic release mechanism which means no additional operating personnel are needed.
- ▶ With height adjustment bars.

Type	Outside Diameter of Pipe D mm (in)	Gripper Length mm (in)	Working Load Limit WLL kg (lbs)	Dead Weight kg (lbs)	Order-Number
RG-20/80 ^①	200 – 800 (7 ³ / ₄ – 31 ¹ / ₂ "	420 (16 ¹ / ₂ "	1,500 (3,300)	92 (205)	5450.0002
RG-8/40 ^①	80 – 400 (3 ¹ / ₄ – 15 ³ / ₄ "	500 (19 ³ / ₄ "	430 (950)	45 (100)	5450.0004



Pipe Laying Hook RLH

Ensures greater safety and saves time when laying pipes.

- ▶ For pipes up to 1 m length.

Standard Specifications:

- ▶ Eyelet for attaching to crane hook.
- ▶ Safety chain
- ▶ Handle for safer insertion into the pipe.

Type	Width W mm (in)	Working Load Limit WLL kg (lbs)	Dead Weight kg (lbs)	Order-Number
RLH-1	190 (7 ¹ / ₂ "	1,000 (2,200)	24 (55)	5400.0001
RLH-3	260 (10 ¹ / ₄ "	3,000 (6,600)	45 (100)	5400.0002

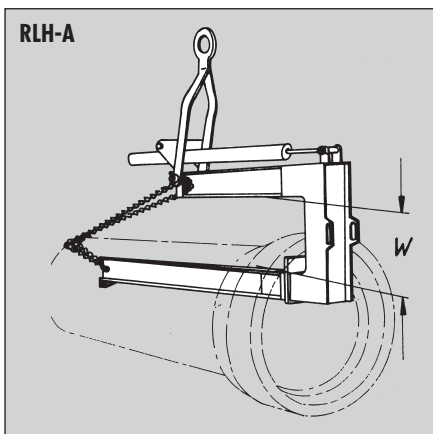

Pipe Laying Hook RLH-A

With automatic center-of-gravity balance and adjustable stop buffer.

- ▶ For pipes up to 3 m.

Standard Specifications:

- ▶ Safety chain
- ▶ Handle for safer insertion into the pipe.

Type	Width W mm (in)	Working Load Limit WLL kg (lbs)	Minimum Load kg (lbs)	Dead Weight kg (lbs)	Order-Number
RLH-1-A	300 (12")	1,000 (2,200)	350 (770)	180 (395)	5400.0010
RLH-3-A	460 (18")	3,000 (6,600)	1,000 (2,200)	310 (680)	5400.0011
RLH-7,5-A	500 (20")	7,500 (16,500)	3,000 (6,600)	730 (1,610)	5400.0012

The stated minimum load is necessary if the automatic center-of-gravity balancer is to function.

① Durable surface protection by galvanizing